

DX SYSTEM
DXR 230 EVOLUTION

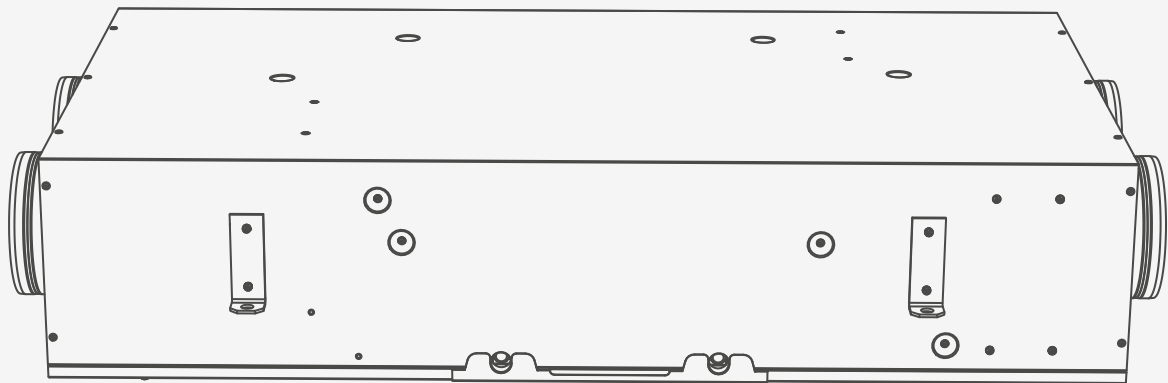

Heat recovery ventilation for ceiling installation



1. Introduction	3
1.1. Warnings	3
1.2. Pictograms	3
2. Description	4
2.1. General information	4
2.2. Construction / Dimensions	6
2.3. DXR Assembling	6
3. Installation	7
3.1. Location of the installation	7
3.2. DXR Unit	7
3.2.1. Location	7
3.2.2. Accessibility	8
3.2.3. Fixing of the DXR Unit	9
3.2.4. Duct connections to the DXR Unit	10
3.2.5. Evacuation of condensates	11
3.3. Defrosting (optional)	12
3.4. Smart interface	13
3.5. 2I2O module	13
3.6. Special care for the ductwork	14
3.7. Fire protection	14
4. Electrical connections	15
4.1. Electrical connection on the DXR Unit	16
4.2. Electrical connection of the defrosting	17
4.3. Electrical connection of the condensate pump	17
5. Starting and settings of the DXR system	18
5.1. Ways to access to the interface	18
5.2. DXR Home page	19
5.3. First start	21
5.4. How to bring up to date the versioning	21
6. Maintenance	22
6.1. Regular maintenance of the installation	22
6.2. Power supply and motor material protections	22
6.3. Filters	23
7. Troubleshooting	25
8. Acceptance of works	26
8.1. Visual inspection	26
8.2. Measurements	26
9. Specific recommendations for airtightness and insulation of the installation	27
9.1. Insulation of the installation	28
9.2. Airtightness of the installation	28
10. Supply and exhaust units	30
10.1. Supply grilles	31
10.2. Exhaust BXC units	31
10.3. Fresh air inlet and exhaust air outlet	32
11. Environmental concerns	32
12. Warranty	32
13. Conformity and standard	32
14. Characteristics	33

1. INTRODUCTION

This document presents the installation and maintenance schemes for the whole system.

1.1. WARNINGS

PLEASE READ THE FOLLOWING INSTRUCTIONS BEFORE THE INSTALLATION:

In case of non-compliance with advice and warnings contained in this manual, the manufacturer can not be considered responsible for damages to persons or property.

The manual describes how to install, use and maintain correctly the appliance. The only way to ensure the efficiency and longevity of the product is to comply with these requirements.

Do not use this appliance for any applications for which it is not intended.

The system must be installed by experienced contractors, trained in the specificities of the process and having the necessary skills in aeraulics and electricity.

The use of gloves to carry on the installation is recommended.

After unpacking the appliance, make sure it is not damaged. Any functional default must be reported to your reseller.

The use of an electrical appliance implies the following fundamental rules:

- Do not touch the appliance with a wet or damp body (hands, feet, etc.).
- This appliance can be used by children aged from 8 years and above and persons with reduced physical, sensory or mental capabilities or lack of experience and knowledge if they have been given supervision or instruction concerning use of the appliance in a safe way and understand the hazards involved.
- Children shall not play with the appliance.
- The electrical installation and electrical connections must be carried out by a qualified technician according to the manufacturer's instructions and in compliance with the characteristics listed on the nameplate of the unit.
- The Appliance shall be installed in accordance with national wiring regulation (IEC60335-2-40).
- Before carrying out any operation on the appliance, unplug or disconnect it from the power supply, and ensure it can not be accidentally restored.
- Power cable modification or replacement must only be carried out by qualified personnel or by After-sales Service in order to avoid any accident.
- Cleaning and user maintenance shall not be made by children without supervision.

1.2. PICTOGRAMS



Warnings
Risks of:
· Appliance damage
· Bad efficiency and longevity of the appliance.



Risk of electric shock.



Electrical component: ground.

2. DESCRIPTION

2.1. GENERAL INFORMATION

The DX System is a range of smart heat recovery ventilation systems that continually supply pollen-free and dust-free preheated fresh air to living areas, ensuring a comfortable feel-good climate.

The DXR EVOLUTION is a heat recovery unit with demand-controlled airflows for horizontal installation (in the false ceiling) in the apartment or in the house, from 2 to 5 main rooms, and from 1 to 5 technical rooms (kitchen, bathroom, others wet rooms). The apartment is limited to 2 floors (1 ground floor and 1 floor maximum), and has a maximum surface of 210 m². This HRV system can also be used in offices, hostels, etc., if the required airflow is in accordance with the one offered by the system.

General working of the DX System, EVOLUTION Version

The DX System is comprised of a heat recovery unit (DXR Unit **1**) connected to exhaust units which control airflows. The counter-flow heat exchanger, integrated into the main unit, ensures the recovery and transfer of most of the energy from the exhaust air to the supply air, thus limiting the energy required to heat the fresh air.

Airflows are automatically controlled according to the needs of each dwelling's room (room-by-room DCV): Outdoor filtered air is supplied **3** in the bedrooms and in the living room. Stale air is extracted **5** from the kitchen, bathroom and WC. On the exhaust side, the BXC units adjust automatically the airflow, according to parameters read by various sensors: humidity (used in the kitchen, in the bathroom and in WC), presence (can be used in WC). Versions with switch, presence, remote, CO₂ or VOC sensors can also be used for exhaust units.

According to the size of the dwelling, the exhaust fan motor provides a constant pressure in the exhaust ductwork that can easily be set from the interface (80 Pa, 100 Pa, 110 Pa or 120 Pa).

At all times, total supply airflows and total exhaust airflows are measured through pressure sensors placed in the DXR unit. The use of electronic pressure sensors allows to calculate with a very high accuracy supply and exhaust airflows without influence of clogging filters or ductwork pressure drops. So, a dedicated micro-controller drives the two fan motors in such a way that supply and exhaust massflows are balanced according to the desired airflow setting point (80 m³/h, 140 m³/h, 200 m³/h or 230 m³/h).

When the outside is mild enough, the bypass, located in the DXR unit **1**, automatically allows to the supply air to be filtered and then to be supplied in the dwelling without going through the heat exchanger, it can also be used in free-cooling mode to provide night cooling in summer.

Specific working of the DXR EVOLUTION version

The EVOLUTION version corresponds to the best HRV solution in terms of energy savings. In this version, the DX System adapts exhaust airflows room-by-room based on specific needs, while balancing supply and exhaust. The exhaust airflows are controlled by humidity sensors or presence detectors or other activators in the exhaust units.

The DXR EVOLUTION allows 4 specific regulation modes :

- **Absence mode.** This mode runs a 40 m³/h airflow ventilation for a duration the customer may choose within a list of 1, 2, 3, 6, 14 or 30 days.
- **Overventilation mode.** This mode increase ventilation airflows staying on the bypass rules. The customer may choose the over ventilation airflows within a list of 140, 200, 230 or 250 m³/h for a duration he can also choose (1, 2, 3, 6, 12 or 24 hours).
- **Free cooling mode or Free warming mode.** This mode is an over ventilation mode enable only if temperature conditions allow to refresh or to warm the dwelling.
- **Stop mode.** This mode allows to stop the fan motors. This mode may be useful, for example not to clog the filters in case of works in the dwelling.



Typical apartment equipped with the DXR Unit, Reference version

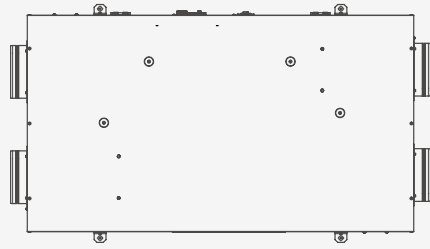

1 DXR Unit
Heat recovery unit with balanced demand controlled airflows

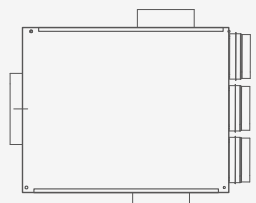

2 Distribution box (not specific)
Passive distribution box for supply airflows (may be replaced with T connections)

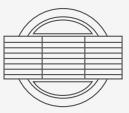

3 SDC 100
Supply unit

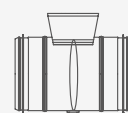

4 Manual register for balancing



5 BXC
Exhaust units (various sensors)

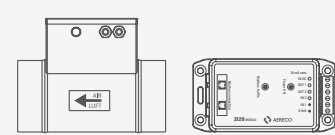

6 Preheater + 2120 Module
Galvanised steel body with built-in resistance (optional)

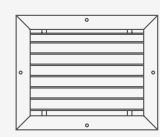

7 Air intake and outlet grilles



8 Acoustic attenuation



9 Smart panel interface
(Optional)

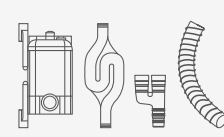

Accessories for condensate evacuation

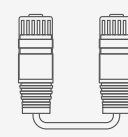

RJ 45 cables

List of components

2.2. CONSTRUCTION /DIMENSIONS

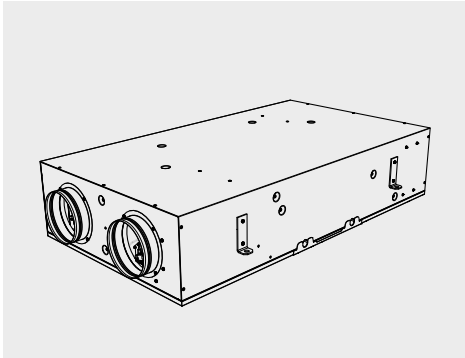

See the characteristics of the DXR Unit system on page 33

- Envelope in galvanised steel
- 2 low energy consumption fans driven by EC electronic motors (supply air and exhaust air).
- F7 anti pollen filter for the fresh air.
- Exhaust G4 filters to protect fans and the exchanger.
- Continuously checking of filter clogging, and warning for filter change.
- High efficiency heat exchanger with aluminium plates, washable.
- Intelligent electronic control unit of the heat recovery, with control interface.
- Integrated bypass and free cooling automatically controlled.
- Flexible duct to drain condensate.

DXR Unit 230 m³/h – Heat recovery unit

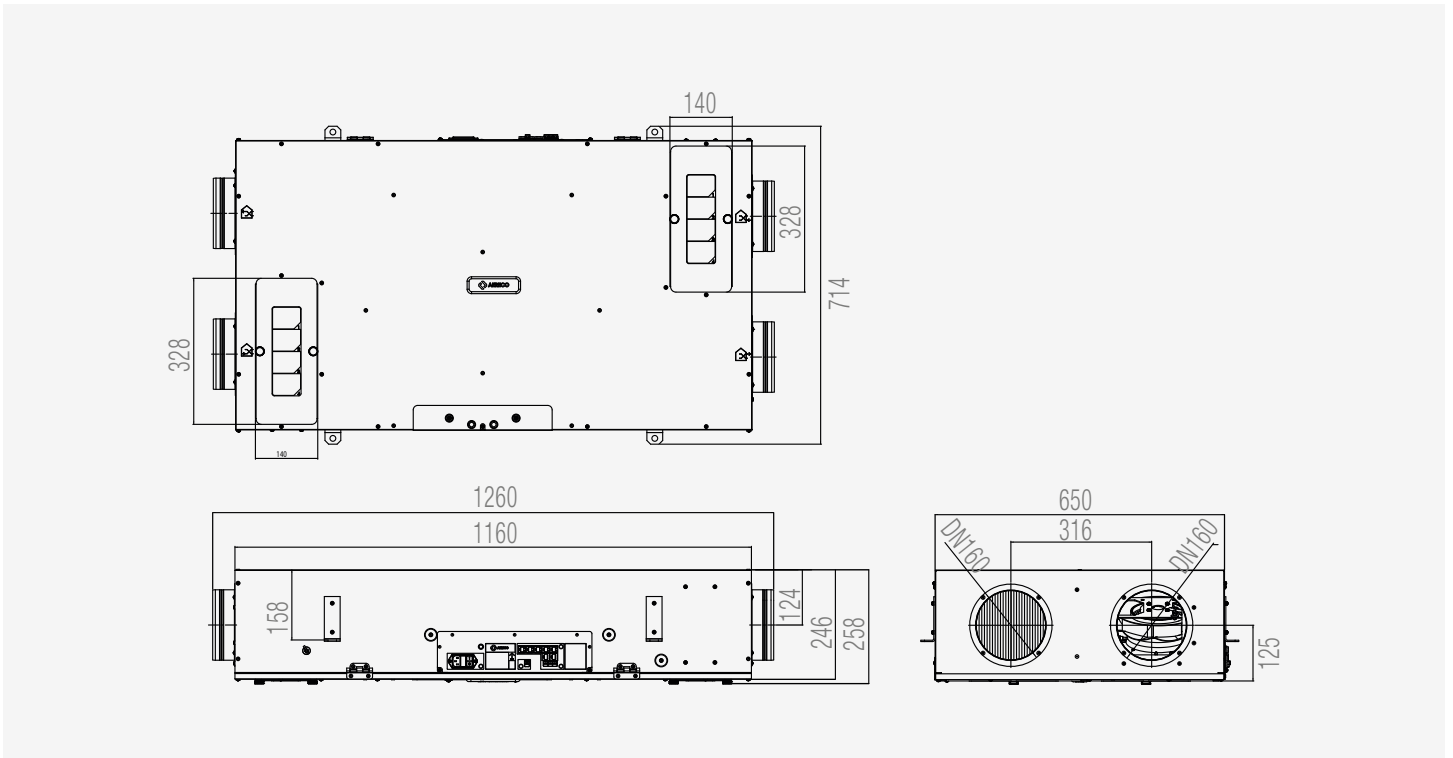

Dimensions of DXR Unit (mm)

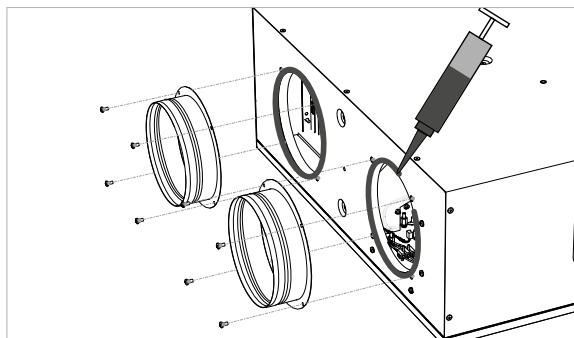

Assembling of the DXR spigots

2.3. DXR ASSEMBLING

When delivered, the DXR unit is furnished with 4 spigots with 4 screws each.
Those 4 spigots have to be screwed and sealed to the DXR unit as indicated on the scheme.
The seal can be made thanks to silicone seal.

Following the seal applied on the DXR Unit, a drying time has to be taken into account before the operability of the DXR.



3. INSTALLATION

3.1. LOCATION OF THE INSTALLATION



The unit must be installed into the heated space, in parts of the dwelling relatively insensitive to noise, not in the unheated space (attic, etc.). Upper and lower temperature limits for the main unit are 5°C and 50°C

Ductwork should be installed in the heated space. If not, they must be insulated with 50 mm minimum of glass wool (or equivalent). The non compliance with these conditions leads to the degradation of the heat recovery performance.

	DXR Unit
Max. altitude of the product installation	2000 m
Temperature range of the installation place	5°C – 50°C
Humidity range of the installation place	5 % - 95 %

3.2. DXR UNIT



The caps on the DXR Unit must stay during the entire duration of the work, in order to keep dust and pollution from getting into the boxes.

3.2.1. LOCATION

Before the installation, be sure of the solidity of the ceiling where you plan to install DXR Unit.

· Weight of DXR Unit = 46 kg

The DXR Unit must be attached so that the gap between the ceiling and the top of the unit is at least 10 mm, and positioned exactly horizontally (max 1° tolerance).



The non compliance to this requirement may lead to serious problems of condensate evacuation.

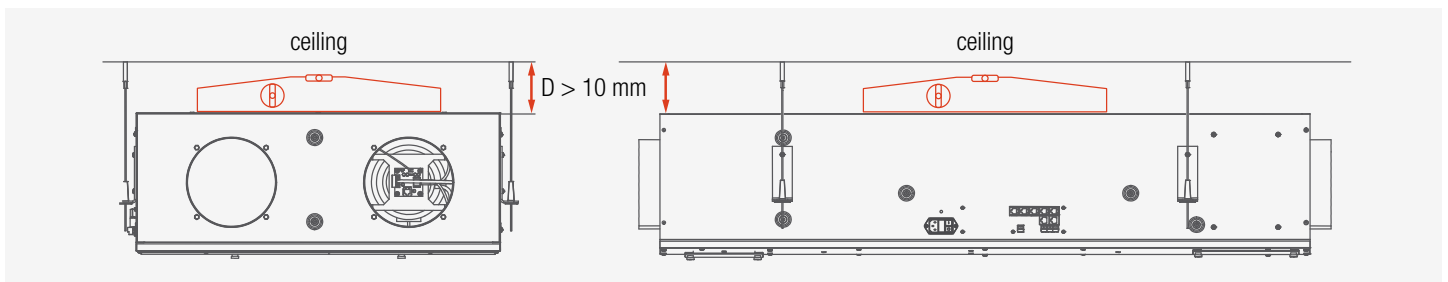

Positioning of the DXR Unit

3.2.2. ACCESSIBILITY



The DXR Unit must be positioned so that it is accessible for the maintenance and in case of access or removal from the wall / false ceiling.

For easy maintenance, leave an access hatch in the false ceiling in order, to have ready access to the hatches of the filters, located under the DXR Unit. The inspection hatch must also be dimensioned so that the DXR Unit can be removed from the false ceiling.

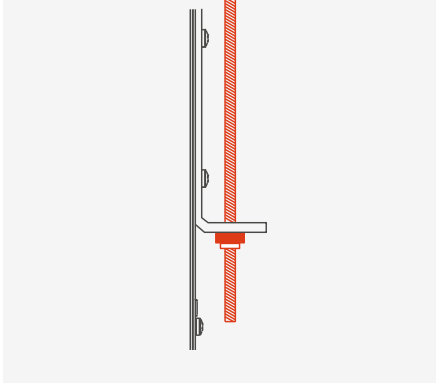

Example of studs

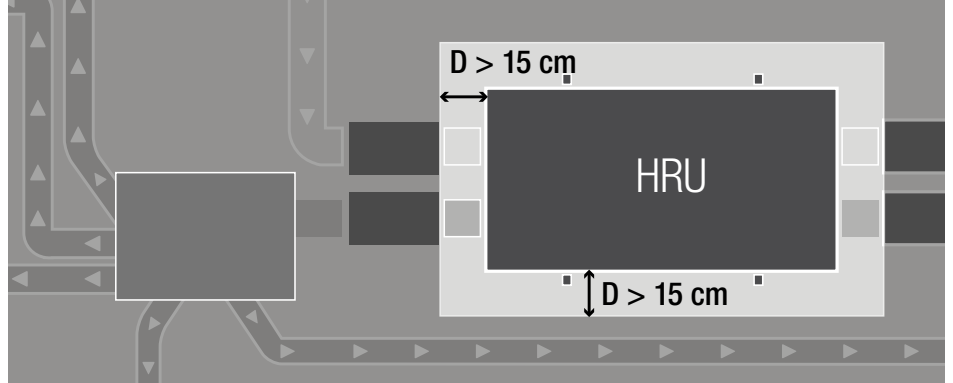

Recommendation for access hatches

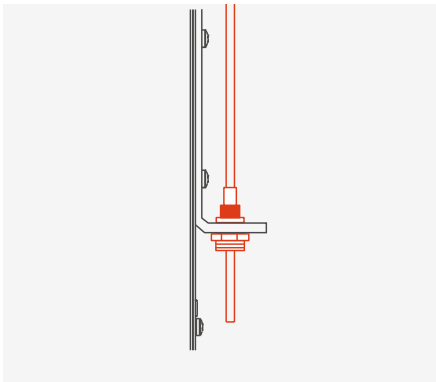

Example of flexible type attachment with auto-blocking system

The electrical connections must be easily accessible to be able to disconnect the DXR Unit from the supply before any operation on the appliance. The circuit-breaker must be easily identified and accessible.

Recommendation: leave an extra 15 cm space around the product to facilitate handling. An extra upper or lower space of 2 cm is also recommended.



The auto-blocking fixation system proposed by Aereco can only be used with a concrete ceiling

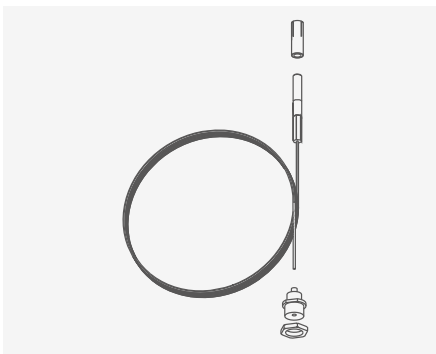

Quick suspension with auto-blocking system proposed by Aereco

3.2.3. FIXING OF THE DXR UNIT

The DXR Unit has 4 brackets for direct fixing to the ceiling, above the false ceiling. When installed on the ceiling, using studs or cables to attach the DXR facilitates precise observance of the positioning requirements.

The auto-blocking fixation system proposed by Aereco can only be used with a concrete ceiling.

Quick suspension with auto-blocking system proposed by Aereco for the DXR Unit (optional, code : ADX1106)

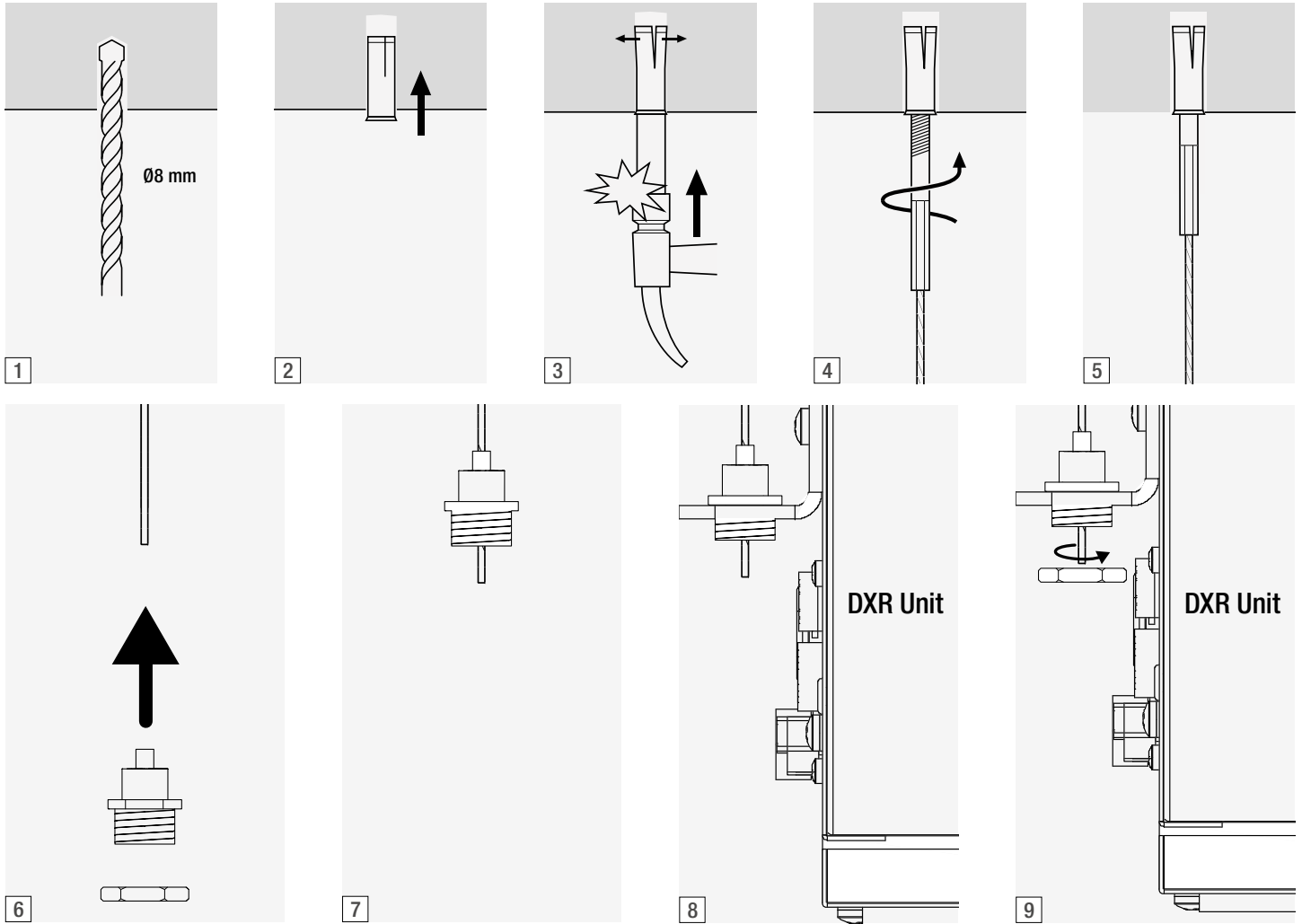

Installation of the quick suspension system

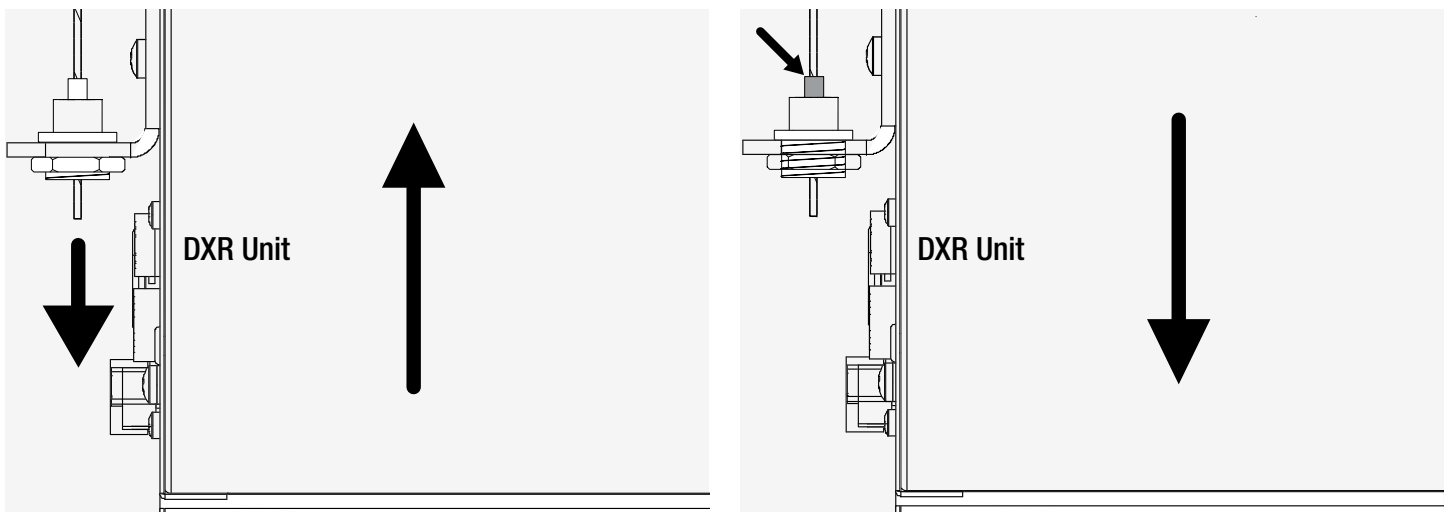

To pull up the DXR: pull the cable downwards

To bring down the DXR: push the top part of the fixation

3.2.4. DUCT CONNECTIONS TO THE DXR UNIT

The connections to the DXR Unit are all in Ø160 mm. Labels on the unit identify the 4 ducts to be connected (fresh air, used air, supply air, exhaust air). **Outdoor fresh air, used air and Supply fresh air ducts must be insulated.**



Be careful to respect top and bottom of the installation.

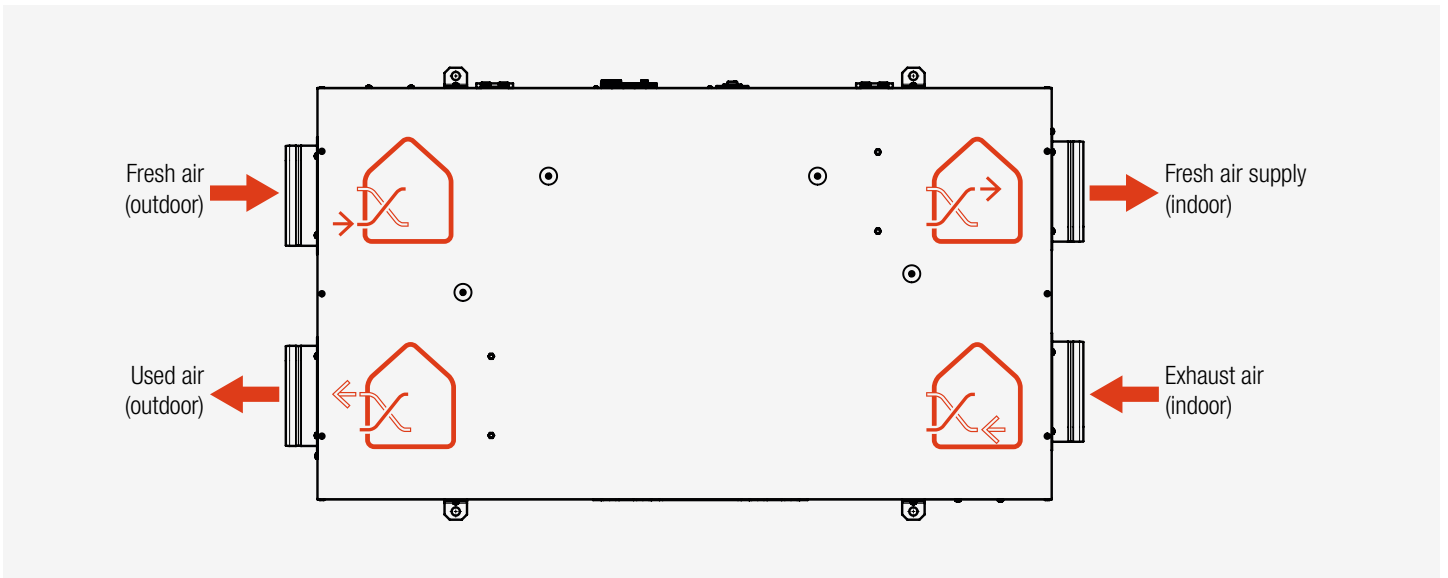

Labels on the unit identify the 4 ducts to be connected (fresh air, used air, supply air, exhaust air). Duct diameters and recommendation concerning the type of ducts



Each supply unit can be connected to a distribution box by a Ø100 mm for rigid duct or by a Ø75 mm duct for semi-rigid duct. Each semi-rigid duct cannot afford an airflow bigger than 30 m³/h.

- 1** Ø100 or Ø75 mm
- 2** Ø100 mm or Ø125 mm
- 3** Ø160 mm
- 4** Ø160 + 50 mm insulation

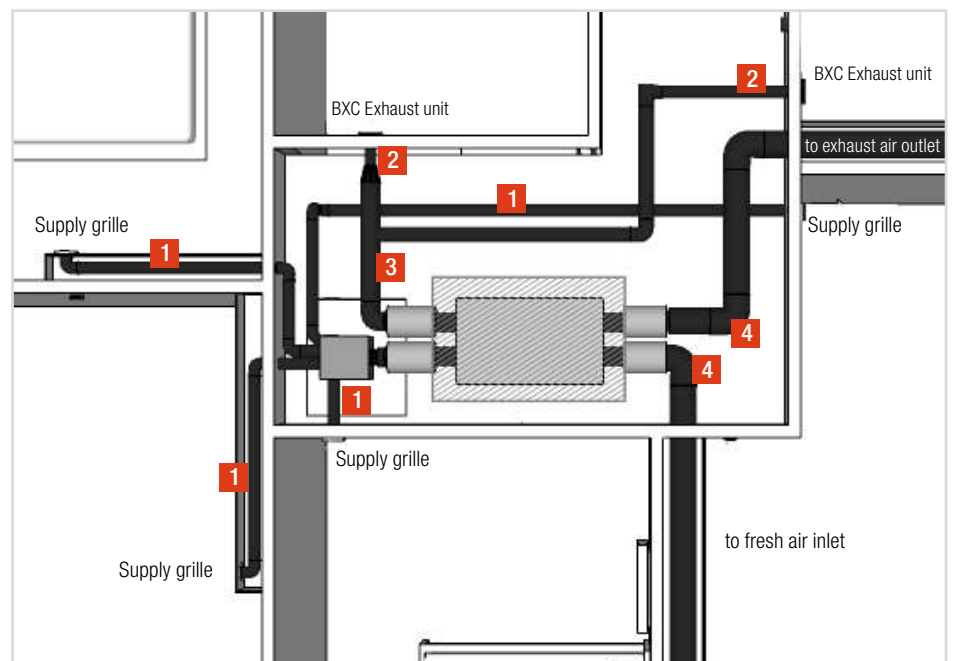

All supply grilles have to be balanced to reach the required airflow in each main rooms (living room, bedrooms....). This may be done by the use of manual registers, blocks of foam, or grilles with nuts inside allowing to adjust room by room supply airflows in each main room.

Duct diameters and recommendation concerning the type of ducts

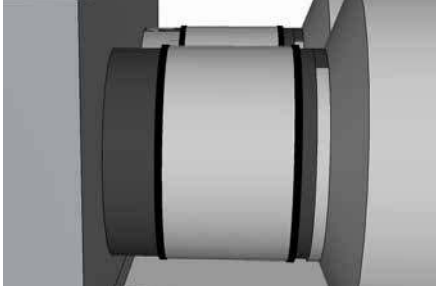

Connection with flexible sleeve

· **If rigid ducts are used, the connection between the DXR Unit and the duct must be made using a flexible sleeve (Ø160 mm), in order to avoid transmitting vibrations from the fan to the duct.**

- Make sure that the flexible sleeve is not twisted or wrinkled and that it is correctly aligned but not completely taut between the unit and the ductwork. To achieve this, it is essential to have a constant section on either side of the sleeve.
- To perform its function of decoupling between the components, the sleeve can be attached by means of flat metallic clamping rings. It will then be necessary to make sure of the airtightness of the assembly.

· **If flexible ducts are used, the connection can be carried on directly to the unit, making sure that the connection is secure and tight with flat clamping rings and adhesive.**



In order to fully guarantee the acoustic quality of the installation, it is necessary to attenuate airborne noise from the main unit by:

- 20 dB at 500 Hz at supply
- 15 dB at 500 Hz at exhaust

This can be done using a silencer or an equivalent length of acoustic duct between the DXR Unit and the Passive distribution box.

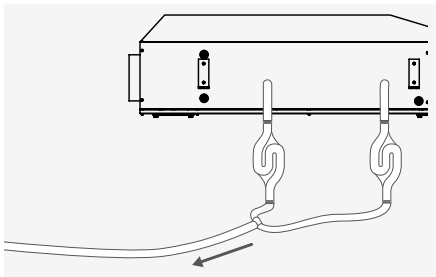

Evacuation of condensates with two siphons

3.2.5. EVACUATION OF CONDENSATES

Condensates must be evacuated to wastewater. This evacuation must be insulated if installed outside the heated volume (risk of freezing). It can be done by gravity with two siphons at the low point, or using a lift pump like the one in the air conditioning unit.

Using a siphon

- Connect the evacuation pipe to wastewater.
- Before first starting up, fill siphons with water.
- Siphons must always be filled with water.

A slope of about 3° is recommended for the good evacuation of condensates. In any case, manufacturer instructions must be followed. The evacuation pipe connection is in Ø16 mm.



The condensate ducts must not be higher than the DXR evacuation outlets.

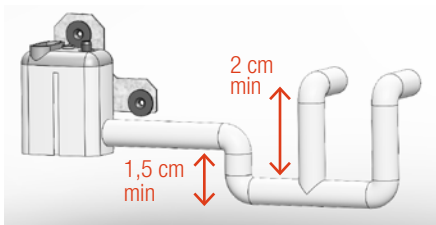

Evacuation of condensates with a lift pump (specific to Aereco)

Using a lift pump

- Connect the condensate pump to the DXR thanks to the metal pieces supplied in the condensate kit.
- Connect the pipes using the metal sheet.
- A vertical height of 8 meters must not exceed between the lift pump and the evacuation duct.

Note: The lift pump proposed by Aereco was tested and validated specially for the DX System. Using another lift pump can lead to serious problems of functioning and degrade the security of the system. **The lift pump connection is in Ø6 mm ID.**

All the connections must be watertight.

3.3. DEFROSTING (OPTIONAL)

The defrosting is located in the duct that serves the fresh air inlet, upstream from the DXR Unit. It is therefore in $\varnothing 160$ mm and insulated. **A minimum length of 1 m must be respected between the DXR Unit and the defrosting. The fresh air supply air duct must be manufactured from non-flammable materials (A1 Class according to EN 13501-1).**



The air must travel in the direction shown by the arrows marked on the defrosting device.

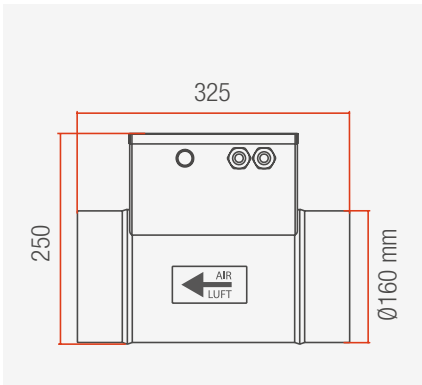

View of the defrosting

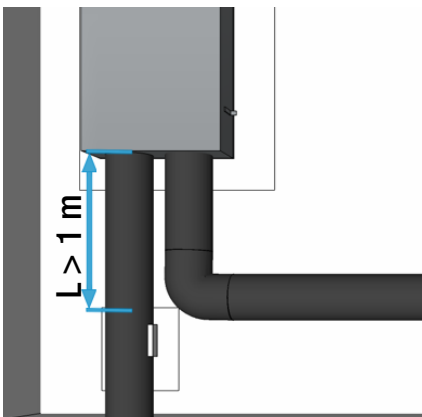

Positioning of the defrosting compared to the DXR Unit

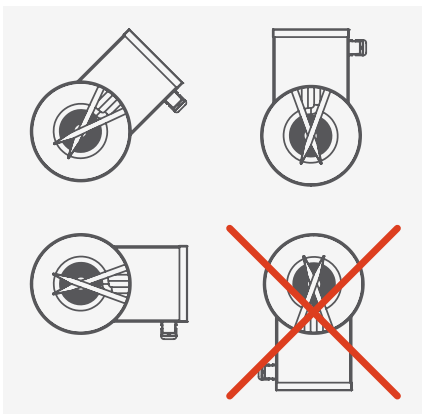

The defrosting must not be installed with the electrical device at the bottom.

The defrosting must be located at a distance of at least twice the connection diameter from a duct bend or external grille, and at 1 m minimum length from the DXR Unit. We recommend tilting the duct slightly towards the exterior in order to keep rain water from getting into the defrosting.

The installation must allow access to the defrosting for a manual reset, or for maintenance (access hatch).

Manual reset of the defrosting:

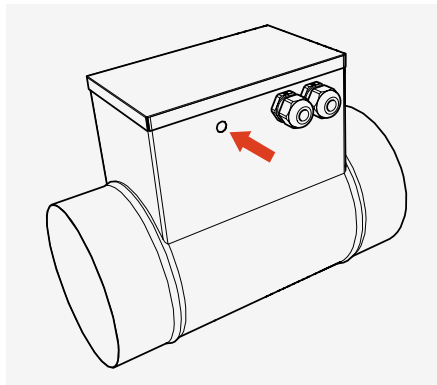

1. Unscrew the black cap

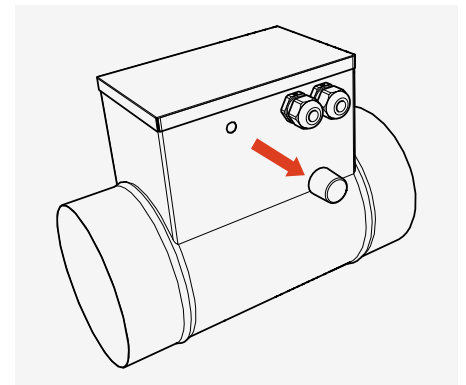

2. Push the red button and screw back the black cap on

Note:

- The DXR Unit has been specially designed to work with the defrosting provided by Aereco (defrost strategy specific to DX System, and adapted diameter). Besides, it has been CEM certified with the DXR Unit.
- Using another defrosting can lead to serious problems of functioning and degrade the security of the system.

Anti-frost without pre-heating resistance

- When using the DXR Unit without the additional resistance pre-heating, the anti-frost strategy is based on the supply airflow regulation. The supply air fan is switched off and the extract air fan remains active, in order to warm up the heat exchanger.

Be careful, very often, this type of strategy does not comply with an open fireplace. Make sure that you comply with the standard in force in the country of installation.

When the optional defrosting device is used, this anti-frost strategy is not active anymore.

A 1200W preheater allows to warm $120 \text{ m}^3/\text{h}$ @ -30°C . If T° can fall down bellow -30°C , 2 x 1200W preheaters may be implemented on the same supply duct network. These 2 preheaters can be driven with only one 2I20 module. In this situation, the amount power of the 2 preheaters is 2400W, so this value has to be entered in the manufacturer access web page (MAINTENANCE / MANUFACTURER ACCESS / Preheater power).

3.4. SMART INTERFACE

As an optional component, a smart interface may be implemented on the bus network. The smart interface allows to enable the automatic mode, the absence mode, or the overventilation mode. The smart interface provides information regarding filters clogging rate and warning messages.

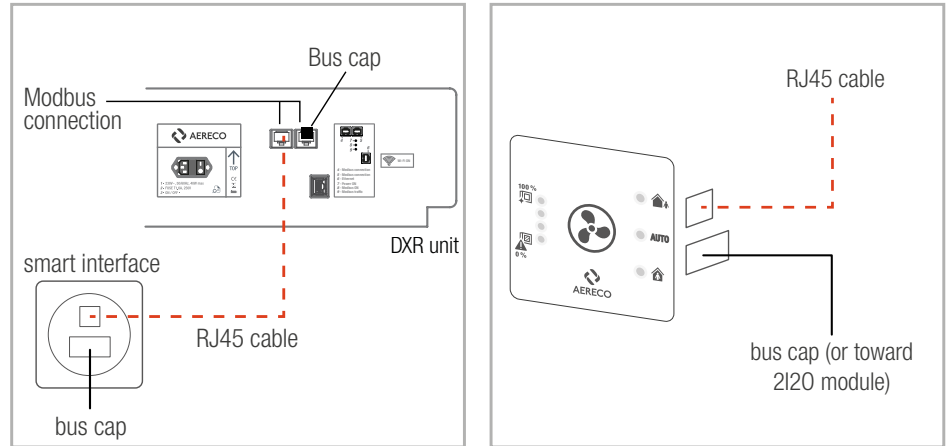

3.5. 2I20 MODULE

- The 2I20 module may be used to display pump warning message on the interface (optional)
- The 2I20 module is mandatory to drive 1 or 2 preheaters
- Only one 2I20 module can be connected on both a pump and 1 or 2 preheater.

Note : On the DXR unit, the RJ45 cable use to link the 2I20 module may be plug into any Modbus connection outlet (up to the installer).

If the 2I20 module is not linked with another module (smart interface for example), a Modbus cap must be plug in the second RJ45 outlet of the 2I20 module.

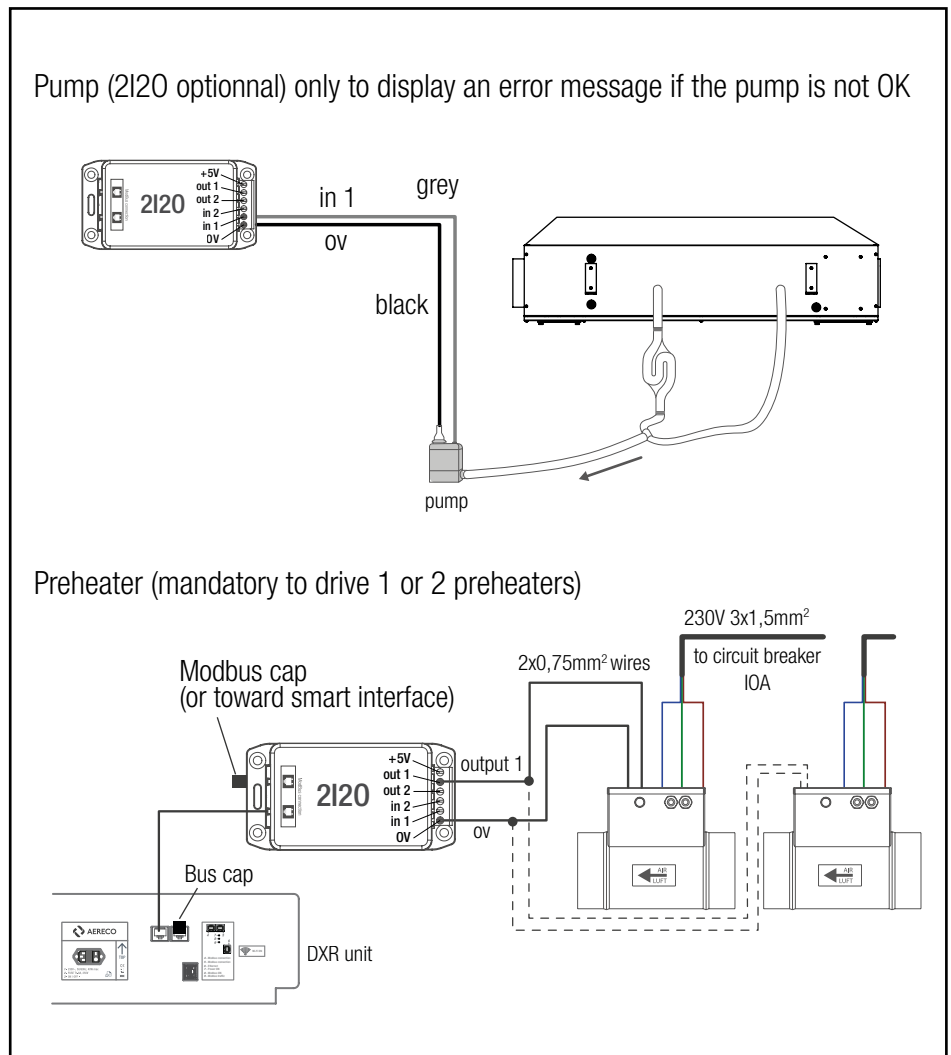

3.6. SPECIAL CARE FOR THE DUCTWORK

Any duct that is outdoors or in an unheated volume must be insulated with 50 mm of glass wool or equivalent. In countries where the temperature can go under -10°C, the recommendation of insulation is at least 100 mm of glass wool.



Mounting of ducts:

- The ductwork must be airtight (see recommendations for an airtight ductwork in page 27).
- Take care not to use a material that is too fragile or too flexible.
- The inner surfaces of all ducts must be as smooth as possible.
- Avoid having too many bends (make them gradual, with a large curvature).
- If using flexible duc:
 - Avoid slopes (flexible ducts must be securely attached).
 - Tauten the straight parts so that the duct is smooth and straight (when using flexible or semi flexible ducts).
 - If the flexible duct is longer than necessary, it must be cut rather than pushing the surplus into the false ceiling.
 - Do not crush the duct or squeeze it down to force it through a narrow passage.
- The interior of the ductwork must be protected during the entire duration of the work (from dust, pollutants, etc.), using caps, plastic bags, or tape.



The installation of supply and exhaust units, and fresh air inlet and exhaust air outlet must be carried out in order to obtain a system that performs well in terms of both aeraulics and thermal and acoustic comfort (see recommendations for the installation of the units in page 27).

3.7. FIRE PROTECTION

The installation must comply with the fire protection standards in force in the country concerned.

4. ELECTRICAL CONNECTIONS



Disconnect the electrical supply before any operations and ensure that the DXR Unit cannot be started accidentally.

Only cables provided by Aereco must be used to carry on the DXR Unit installation. If using different cables, Aereco won't be able to guarantee the good functioning of the appliance.

The installation must be carried out by a professional in compliance with applicable regulations in force in the country of installation. Each product or component used in the installation must also comply with standards in force in the country.

A	DXR Unit
B	Smart interface
C	2I20 module
D	Defrosting
E	Lift pump
- - -	RJ 45
- - - -	Supply (230 V): 1.5 mm ² .

Note: RJ45 cables provide both supply and connections.

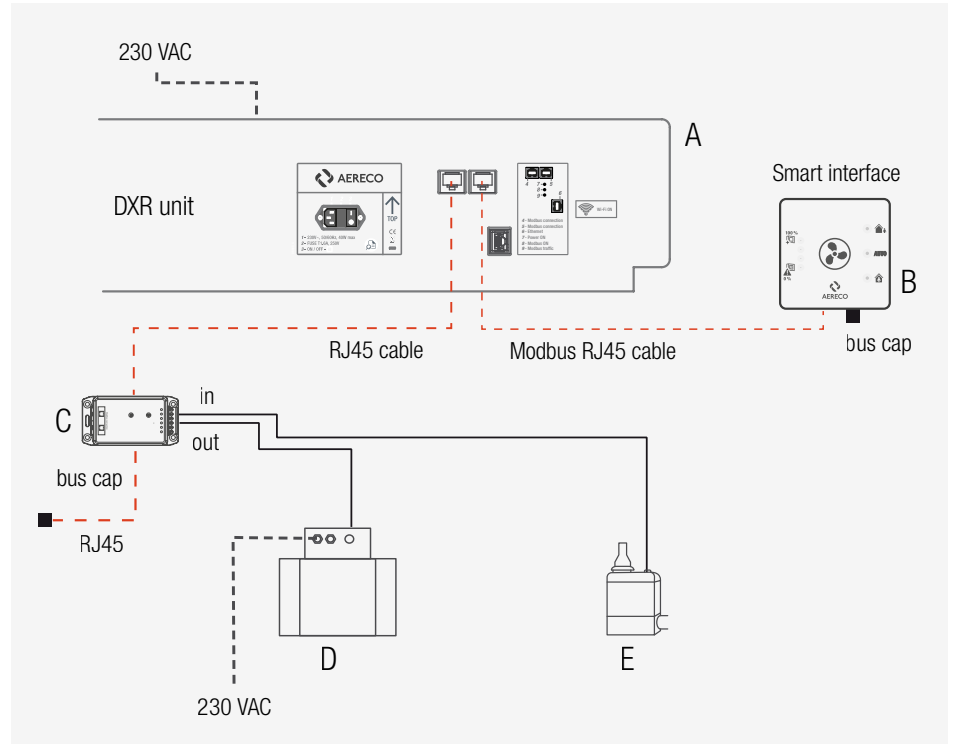

RJ45 maximal length: loop = 100m



ModBus components (2I20 module or smart interface) may be connected on one of the 2 RJ45 ModBus socket (the one you want, it doesn't matter) for a parallel wiring. But the ModBus components may also be connected one after the other for a serial wiring, up to you.

Each modbus line must be ended with a ModBus cap. So, 2 ModBus caps must be connected on the ModBus network (because 2 RJ45 ModBus sockets on the main electronic board).

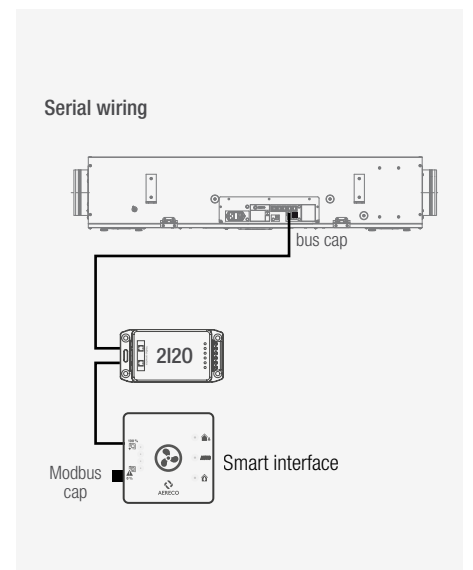
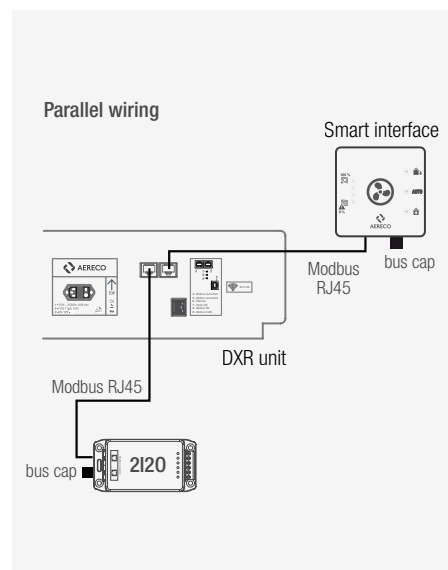

Note: It's possible to connect the smart interface and the 2I20 module with a parallel or a serial wiring.

4.1. ELECTRICAL CONNECTION ON THE DXR UNIT

1	DX ModBus (RJ 45)
2	Ethernet
3	230VAC, 50/60Hz, 180W max
4	ON / OFF

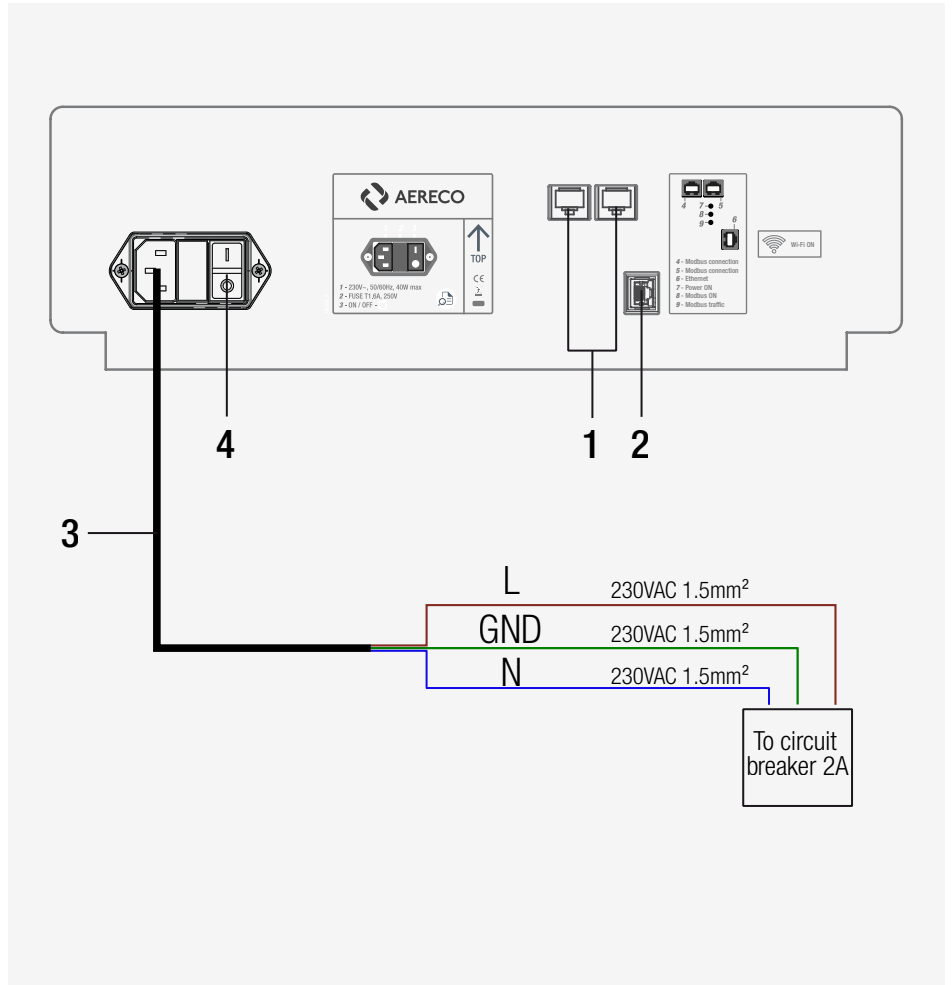

The main power supply is on the DXR Unit.

Smart Interface (optional) and 2I20 module (if pump or preheater).

4.2. ELECTRICAL CONNECTION OF THE DEFROSTING

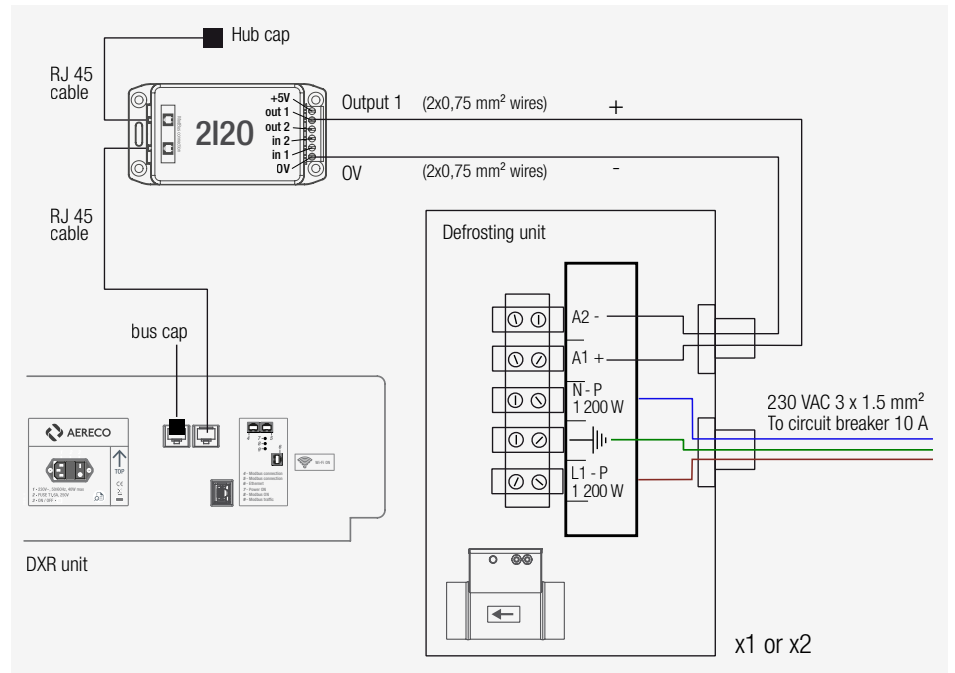

One of the 2 RJ45 Modbus socket may be used for the 2120 connection, and a modbus cap must be plugged on the other RJ45 Modbus socket.

Details of DXR Unit and defrosting connection

The defrosting has an individual supply in 230 VAC, 50/60 Hz, single-phase via a flexible cable having a cross-sectional area of at least 1.5 mm². The control is connected via a 2 wires cable having a cross sectional area of at least 0.5 mm² and a maximal length of 30 meters.

The electrical connection must be made by a professional and comply with the standards in force in the country of installation. Plan a contact separation device having an opening distance of at least 3 mm on each pole.

Note: there is no alarm in the defrosting provided by Aereco.

4.3. ELECTRICAL CONNECTION OF THE CONDENSATE PUMP

The DXR1708 is provided with a siphon. It is still possible to connect a condensate pump after the siphon. The diagram below displays the electrical connections.

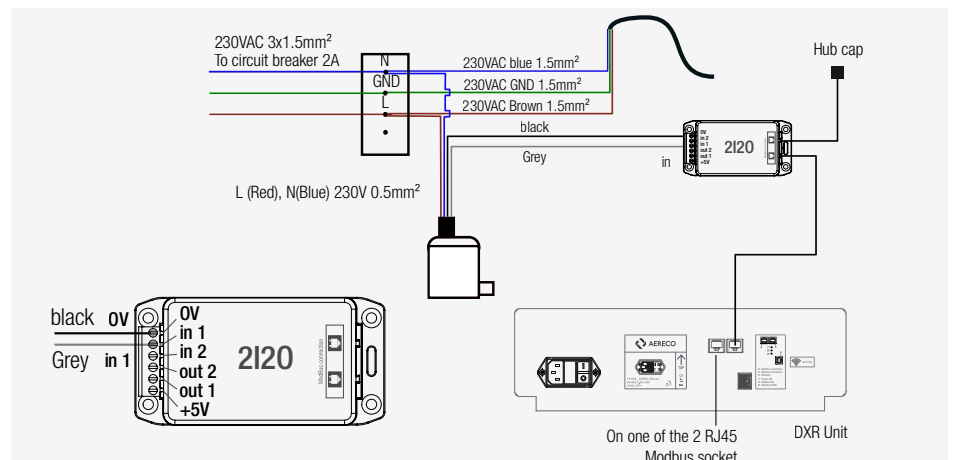

Details of condensate pump electrical connections



Dry contact alarm connections.

The alarm is connected via a 2 wires cable having a cross sectional area of at least 0.5 mm² and a maximal length of 30 meters.

5. STARTING AND SETTINGS OF THE DXR SYSTEM

5.1. WAYS TO ACCESS TO THE INTERFACE

Two kinds of connection are possible to access to the DXR's interface.

1) Communication through ethernet RJ45 cable

The RJ45 cable has to be plugged, on one side, in the DXR RJ45 socket (see scheme below) and, on the other side, in the laptop's or computer's RJ45 socket.

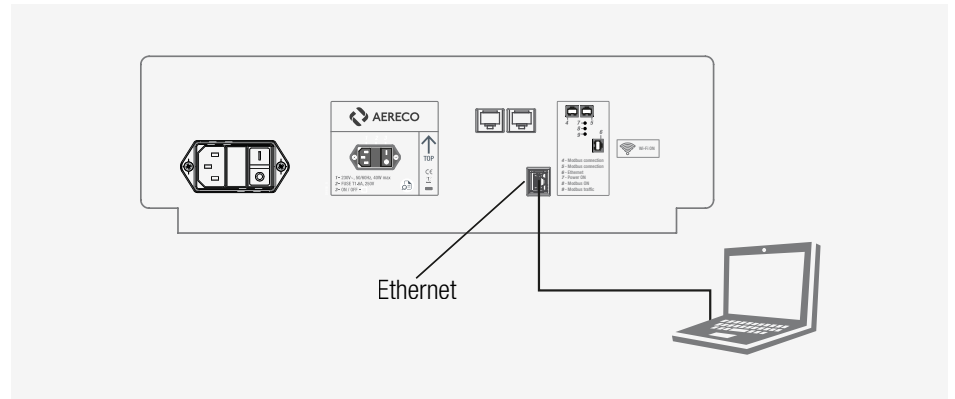

From windows explorer, in the network, click on the DXR icon: another way is to use internet browser.

On internet browser address bar (Edge, Chrome, Safari...), the following addresses give an access to the settings and to the user home page of the DXR interface:

- <http://169.254.1.20/> to go to the Home page,

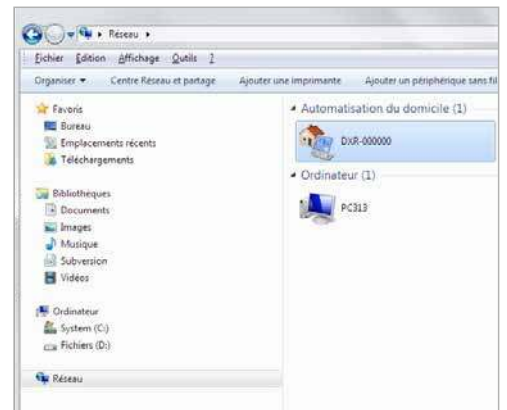
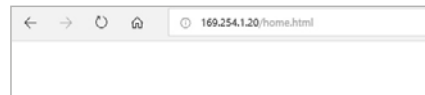

2) Communication through Wi-Fi connexion

From any smartphone or from a computer (or laptop), access to the available Wi-Fi network.

- Select the WiFi network named "DXR"
- The password to the DXR WiFi is: **12345678**
- On the device internet browser address bar (Android, Chrome, Safari...), the following addresses give an access to the settings and to the user home page of the DXR's interface:
- <http://dxr-mb.lan/> to go to the Home page,



5.2. DXR HOME PAGE

1) HOME

The Home page gives a clear overview of the system :

- current mode of operation
- direct way to access

2) MAINTENANCE

To get in this section, the following mentions must be used

USER : 0aereco
PASSWORD : 0aereco123

- Wifi connection

- to select the the Wifi / mode :

- AP mode (Access Point mode). The DXR unit provides its own Wifi network to be accessed with a smart phone, a laptop, or a touch pad.
- ST mode (Station mode). The DXR unit is connected on the home internet box to access internet

This menu allows :

- To enable or disable the DXR Wi-Fi,
- To change the name of the DXR Wi-Fi (named DXR when the DXR unit is delivered),
- To change the Wi-Fi password (12345678 when the DXR unit is delivered).

- System parameters

This menu allows to access 4 advanced tools.

- Synoptic. This advanced tool allows to have an overview of the whole system, with all parameters displayed. It's also possible, with the set BUS values menu, to take under control all driven parts (bypass, fan motors, defrosting unit).
- Synoptic data charts. This tool allows to display the evolution of the device parameters.
- Configuration wizard. The wizard allows to proceed to the DXR settings. Before starting to run the DXR, make sure that all the ductwork have been correctly done. The Modbus communication cable supplies the 2I20 module (if pump or preheater) and the smart interface (if smart interface).
- Reset. This erase all configuration data kept in memory. A new configuration setting by the use of the wizard is required after a reset.

- Maintenance

- Filter clogging level
- Filter status. Reset filters each time filters are replaced
- Bypass
- Preheater

- Manufacturer access.

- K factor is use to adjust airflows. (K=100 for DXR)
- Filters clogging threshold allows to display a warning message
- Preheater set point is the target to drive the preheater. This target is the average value of the 2 cold T° (1/2 x (outside airflow T° before heat Exchanger + Inside airflow T° after heat exchanger). This target is 1°C for the DXR when delivered by the factory.
- Preheater 1200W if 1 preheater (-30°C) / 2400W if 2 preheater (-60°C)
- Exterior T° set point fixes the minimal exterior T° to proceed free cooling (risk of condensates in the ductwork if T° is too low) and if supply ductwork is not insulated.
- Interior T° set point to manage the bypass.

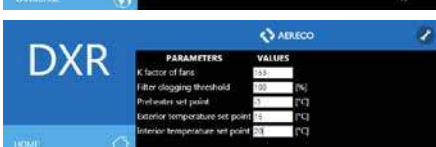
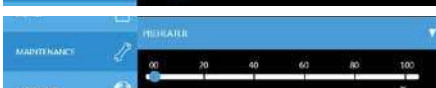
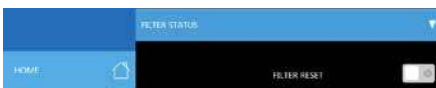
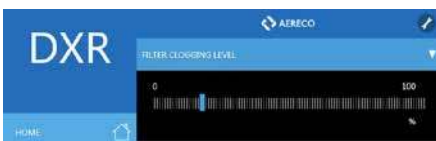
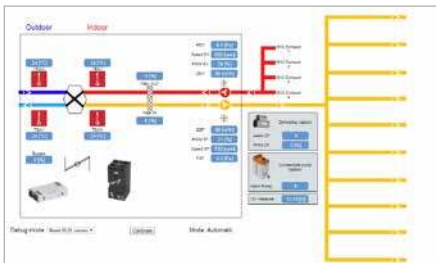
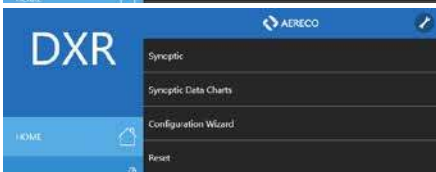
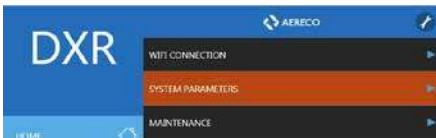
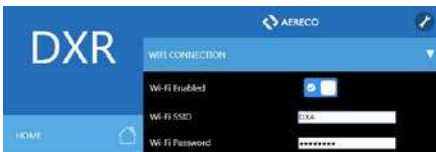



- General settings

- Email account settings

The emailing feature aims the communication of a possible system warning or a fatal error to the interested people. We suggest one email address should specify the owner's one and the second email address should specify the technician in charge of the maintenance. The contact field may contain some information providing the maintenance technician with the needed customer contact.

The essential points describing the emailing feature are:

1. The emailing of the warnings feature may be enabled/disabled.
2. When enabled, the system send email to one, two or three recipients. Two recipient email addresses are configurable. The third recipient is the manufacturer, it is predefined and it is mandatory when you enable this feature.
3. There is a button to test the configuration. When you click it, the system sends email letting you to check the connectivity.
4. The information sent is:
 - a. Date and time,
 - b. Recipients email addresses
 - c. The text from the contact field
 - d. The status of the system including the event, the devices composing the system, their serial number, hardware version, software version, functioning parameters when the event happened. The status information is sent as a link onto the manufacturer cloud.
5. The manufacturer collects only the status information in anonymous fashion. The text from contact field and the email addresses are discarded.
6. To be able to email, the system needs to be connected to Internet through the local LAN (Station Mode)
7. If you are concerned about the privacy issues you may simply disable the emailing system.

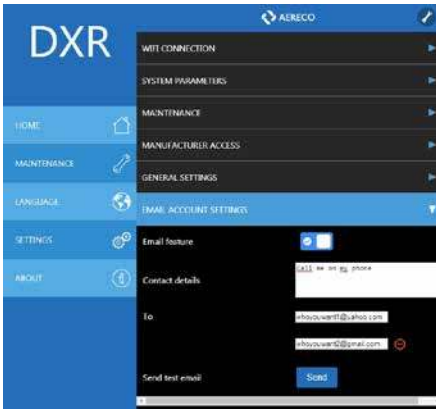

3) LANGUAGE :

Shortcut to Maintenance / general settings with no need of user name and password.

4) SETTINGS :

This menu allows to configure Automatic mode, free cooling mode, Boost mode, Absence mode and Stop mode within a choice of airflows set points and duration set points.

Automatic mode, the DXR unit drives the exhaust fan motor in such a way that pressure is a constant pressure at the exhaust (-80Pa, -100Pa, -110Pa or -120Pa). At the supply, supply fan motor runs in such a way that at all time, amount exhaust airflows and amount supply airflows are mass-balanced.



Free cooling / free warming mode. Free cooling, if the inside T° is over the inside T° set point, and if the outside T° is lower the inside T° set point, the DXR unit by pass the heat exchanger in order to pulse with a constant airflow cool air coming from outside in the dwelling. Free warming, if the inside T° is lower the inside T° set point, and if the outside T° is higher the inside T° set point, the DXR unit by pass the heat exchanger in order to pulse with a constant airflow hot air coming from outside in the dwelling. When these situations occurred, the free cooling / free warming mode increases airflows to reach the airflow set point. Be careful, if the free cooling / free warming mode is enabled, the DXR unit doesn't run with a constant pressure on the exhaust. The constant airflow the DXR unit has to reach in the free cooling / free warming mode may generate noise pollution on the BXC exhaust units. If too many noises, stop the free cooling / free warming mode, or decrease the airflow set point value. When the free cooling / free warming is enabled, if the T° conditions are not compliant, the DXR unit keep an automatic regulation, waiting the T° conditions to be compliant.

Boost mode, automatic mode with a constant pressure on the exhaust is stopped and a constant airflow regulation is run to boost the ventilation. Be careful, if the boost mode is enabled, the DXR unit performed a constant airflow mode that may generate noise pollution on the BXC exhaust units. If too many noises, stop the boost mode, or decrease the airflow set point value.

Absence mode, a 40 m³/h constant airflow is performed all the mode long.

Stop mode, this mode allows to stop the 2 fan motors. This mode may be very useful, especially when works in the dwelling. This mode allows not to clog the filters.

5.3. FIRST START

At the first start, launch the WISARD application in:

- MAINTENANCE
- SYSTEM PARAMETERS
- Configuration Wisard.

If required (alarm message displays on the interface) and only if required, calibrate the pressure sensors in the Synoptic application (MAINTENANCE / SYSTEM PARAMETERS / synoptic).

Before calibrating, be sure there is not airflow at all in both supply and exhaust ducts networks. If no airflow, press on the calibration button.



The calibration operation must be performed by a skilled operator only

5.4. HOW TO BRING UP TO DATE THE VERSIONING

With an ethernet connection, from the computer's internet browser, go to the WEB page <http://169.254/1/20/webupgrade>

USER : (only for the manufacturer staff)

PASSWORD : (only for the manufacturer staff)

Then, load the 4 files to bring up to date the whole device.

In case of major issue (fatal issue after upgrade), restart the device with the SOS version by 5 x (switch OFF - switch ON)



The upgrade operation must be performed by skilled operator only

6. MAINTENANCE



For every operation of maintenance, even replacement of filters, disconnect the electrical supply before any operation and ensure that the unit cannot be started accidentally.

Maintenance of ventilation installation helps to avoid:

- microbial contamination of the installations, with consequences on comfort and health (the impact of such contamination is aggravated in an air supply);
- loss of aeraulic performance through too high pressure drops, increase of fan consumption;
- noise (from a too high pressure, and from high speed rotation of fan due to clogged filters).

6.1. REGULAR MAINTENANCE OF THE INSTALLATION

Frequency	Maintenance
when the alarm indicates it	Replace the filters, then reset filters in the MAINTENANCE MENU.
	Fresh air inlet and exhaust air outlet: check the unobstructed passage of air (no dead leaves, no snow).
	Supply and exhaust units: cleaning as recommended by the manufacturer (this part can be done by the occupant).
once a year	Evacuation of condensates: check that the system is not obstructed by impurities. WARNING: Plan replacement of the condensates evacuation pump according to the life span announced by the supplier. If using a DXR Unit with a built-in siphon, check that siphons is filled with water. If not, it is necessary to fill the siphon with water.
	Ductwork: check and cleaning if the ductwork is obstructed.
	Exchanger: check the exchanger and clean it with a vacuum cleaner, only if necessary.
once every 5 years	Fans: <ul style="list-style-type: none"> · check the blades · check and cleaning if the grilles protecting the fans are obstructed

6.2. POWER SUPPLY AND MOTOR MATERIAL PROTECTIONS

In case of dysfunction of the appliance, these protections will be turned on. It is then necessary to disconnect the appliance during 30 seconds to restart the DXR Unit.

6.3. FILTERS

The interface indicates when the filters need to be changed. Their change is easily realised through the two access hatches (no tool needed).

The bottom cover of the DXR Unit must not be dismantled for this operation. All filters (1xG4 and 1xF7) must be replaced at the same time.

Filter removal/replacement:

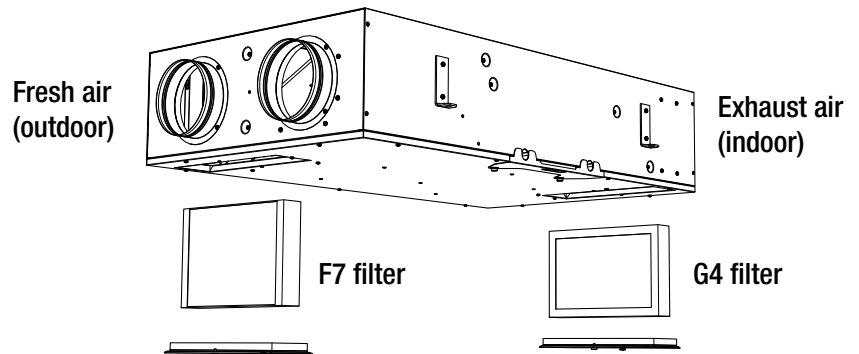

Removal

1. Switch off the unit.

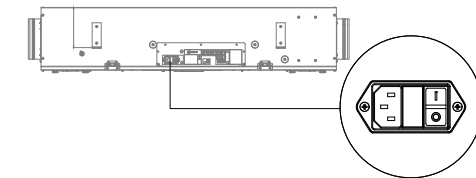

2. Remove both filter hatches
Remove 2 fixing buttons. Hold the hatches with you hand to prevent it from falling.

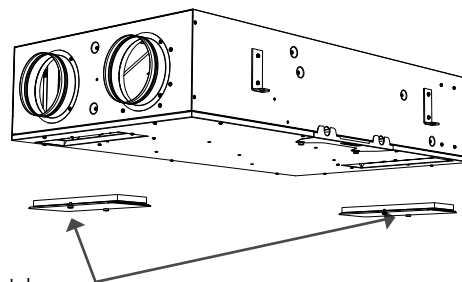

3. Remove each filter by holding it firmly along its edge and pulling it downward out of the filter slot (the filter is a push-fit item and not fastened in place).

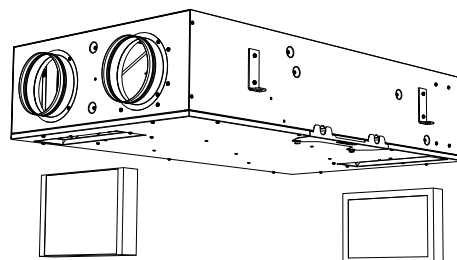

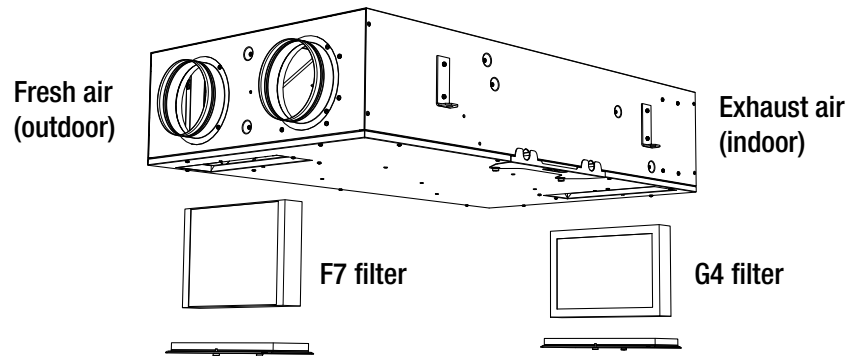

Replacement

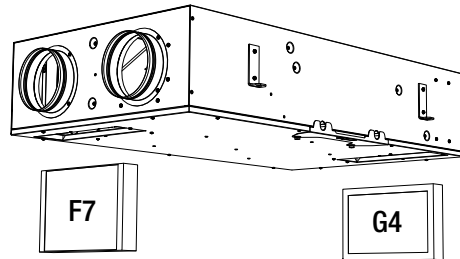

1. Ensure that the new (clean) filters are positioned in the right order.
 - G4 filters: the inscription "dust air side" on the filter must face the incoming air.
 - F7 filter: the arrow on the filter must follow the supply air path.
2. Ensure that the new (clean) filters are firmly pushed back into their slots.

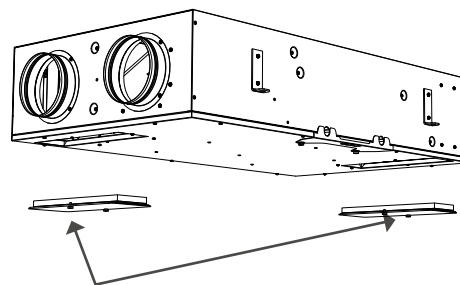

3. Replace the access hatches with 2 screws.

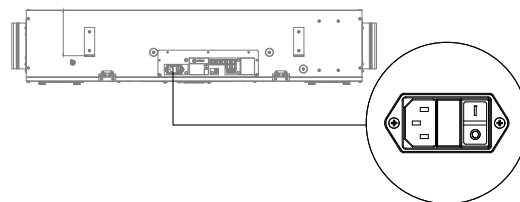

4. Switch on the unit
5. Reset the filters in the MAINTENANCE : menu MAINTENANCE / filters status / filter reset

7. TROUBLESHOOTING

Faults	Causes	Actions
Condensate leaks or water noise in the heat exchanger	Poor condensate evacuation	Make sure the external pipes have been installed properly. Siphon has to be full of water.
	Poor condensate evacuation (Using a lift pump)	Make sure it is correctly working according pump's manual.
Low airflow levels at grilles	Network leaks	Inspect the aeraulic network and sealing.
	Bypass open	<ul style="list-style-type: none"> - Make sure the bypass is in good condition and the motor is operating properly. - Re-start the DXR Unit by disconnecting it during 30 seconds from power. - Control filter clogging, and if necessary, replace them. - Check with the synoptic tool all T°
Cold incoming air supply	Defrosting default Supply ductwork insulation	<ul style="list-style-type: none"> - Make sure the airflow rate is not too low. - Check the unobstructed passage of air in the defrosting - Make sure ductwork are placed in a warm area or they are properly insulated.
The motors are not working	Power supply	Make sure the DXR Unit is connected to the main electrical board.
	Aeraulic network not connected	Connect the network
	Pressure loss or major leakage on the network	<ul style="list-style-type: none"> - Improve the network installation, use the recommended grilles and roof exhausts - Be sure to respect the recommendations of installation
The motors are running too fast	Too high number of extraction grille	Check the operating limits
	Filters are clogged	Make sure filters have been changed when system asked for it.
The system makes noise of vibrations	Heat exchanger is frozen (Using a defrosting)	<ul style="list-style-type: none"> - Make sure the defrosting is connected to the 2I2O module and to the main. - Make sure the defrosting is taken into account in the parameters of the DXR Unit user's interface. - Make sure the manual reset of the defrosting has not been triggered. In case it has been triggered, check the unobstructed passage of the air near the defrosting before resetting the security.
	The Unit is fixed in the wrong way	Make sure the system is fixed as explained in the recommendations of installation
How to reset the device ?	Configuration may be changed by launching the Wisard application (parameters remain the same)	<ul style="list-style-type: none"> - To erase all parameters, proceed a reset in MAINTENANCE / SYSTEM PARAMETERS / RESET. Then, launch the Wisard application. Parameters have to be set again (Pressure / T° set points, durations, K factors, etc.)

8. ACCEPTANCE OF WORKS

8.1. VISUAL INSPECTION

GENERAL		Remarks
Supply units in every main rooms (living room, bedroom) (accessibility)	<input type="checkbox"/>	
Door relief vent (2 cm in the kitchen, 1 cm in every other rooms)	<input type="checkbox"/>	
Exhaust units in the utility rooms (accessibility)	<input type="checkbox"/>	
Positioning of the defrosting in the fresh air duct (direction shown by the arrows)	<input type="checkbox"/>	
Access hatch for the defrosting if preheater	<input type="checkbox"/>	

DXR UNIT		Remarks
Accessibility for the DXR Unit	<input type="checkbox"/>	
Positioning of the DXR Unit (vertical) and fixation of the DXR Unit to the wall	<input type="checkbox"/>	
Conformity of connection (direction shown by the arrows on the DXR Unit)	<input type="checkbox"/>	
Connection sleeve at the DXR Unit and airtightness of the connections	<input type="checkbox"/>	
Exhaust air and fresh air duct (insulated and Ø160 mm)	<input type="checkbox"/>	
Exhaust balancing (in each utility room)	<input type="checkbox"/>	
Supply balancing (in each utility room)	<input type="checkbox"/>	
No spilages on the exhaust duct network	<input type="checkbox"/>	
No spilages on the supply duct network	<input type="checkbox"/>	

ELECTRICAL DEVICE		Remarks
Supply voltage	<input type="checkbox"/>	
Ground connections	<input type="checkbox"/>	
Individual electrical connection for electrical device (defrosting, DXR Unit)	<input type="checkbox"/>	

START		Remarks
Working of the interface	<input type="checkbox"/>	

8.2. MEASUREMENTS

If some measurements are planned on the project, it is recommended to measure for acceptance of work:

- the airflow rates in each main room (supply) and each utility room (exhaust),
- the airflow when supply and exhaust ductworks are stopped up (spilages measurement), (<40 m³/h with PWM fanmotors = 80% in the synoptic advanced tool)
- possibly, the sound level in the main rooms and very close to the fans,

9. SPECIFIC RECOMMENDATIONS FOR AIRTIGHTNESS AND INSULATION OF THE INSTALLATION

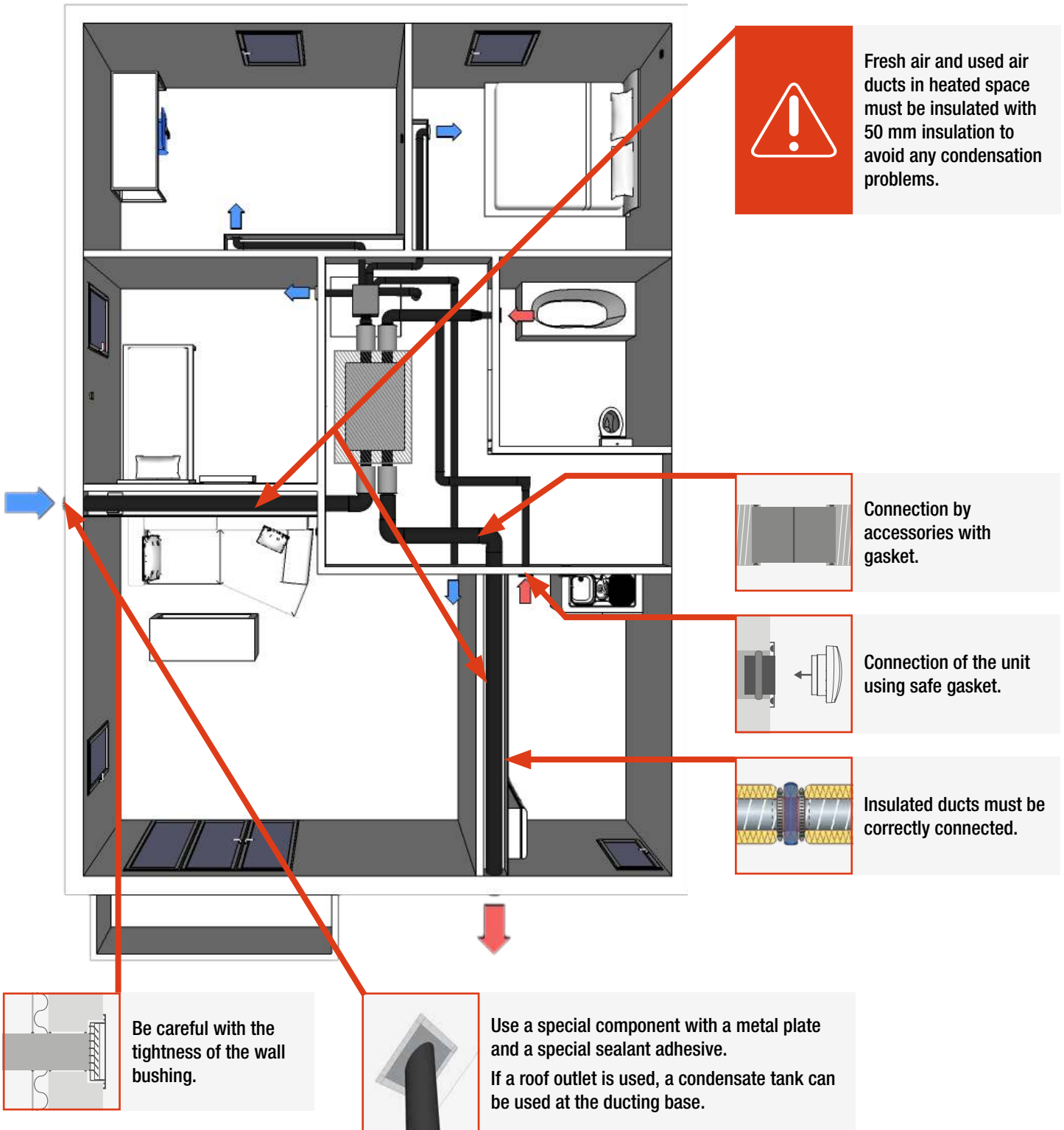

!
Fresh air and used air ducts in heated space must be insulated with 50 mm insulation to avoid any condensation problems.

!
Connection by accessories with gasket.

!
Connection of the unit using safe gasket.

!
Insulated ducts must be correctly connected.

!
Be careful with the tightness of the wall bushing.

!
Use a special component with a metal plate and a special sealant adhesive.
If a roof outlet is used, a condensate tank can be used at the ducting base.

!
To remain airtight in the long term, the ductwork must be mechanically strong (attachment between duct elements) and correctly supported. Failing this, the sag may eventually crack the mastic.
Any duct carrying hot air that is outdoors or in an unheated volume must be insulated with 50 mm of glass wool or equivalent.

9.1. INSULATION OF THE INSTALLATION

In cases where the ductwork must be insulated, the use of prefabricated double wall ducts and accessories should be favoured to obtain good thermal performance.

External insulation on site is possible, **but care must be taken not to create thermal bridges, and the insulation must be attached securely enough to prevent its moving.** This is quite tricky on shaped parts, singularities, branch, ducts, etc.

- Step **1**: ensure airtightness of the internal face of the duct by glue or tape.
- Step **2**: tighten with a clamp, so that the connection is mechanically strong in the long term.
- Step **3**: pull the insulation to avoid thermal bridges.
- Step **4**: tighten the insulation with a clamp, to avoid its removal.
- Step **5**: if two ducts are to be connected, use an adhesive tape to airtight the two pieces of insulation.

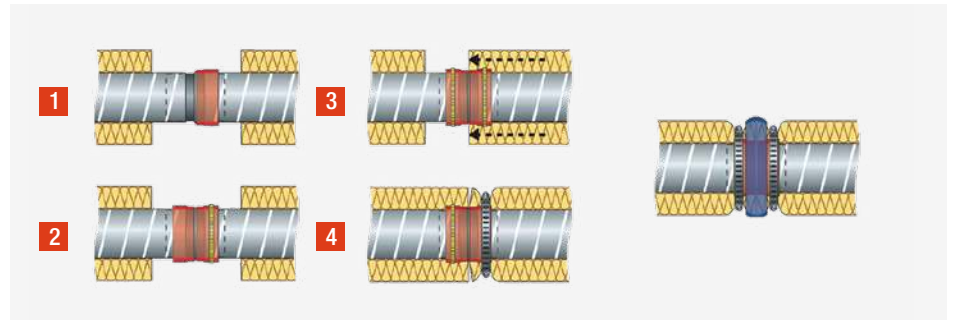

Connection of insulated ducts © CSTB

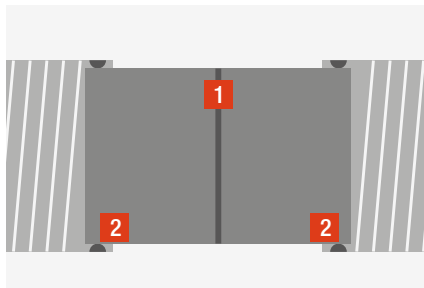

Connection by accessory with gasket

- 1** Connection with gaskets
- 2** Gaskets

9.2. AIRTIGHTNESS OF THE INSTALLATION

To make ductwork sufficiently airtight, the use of prefabricated accessories with gaskets is an ideal solution (bends, junctions between ducts).

The use of such hardware also facilitates the installation of the ductwork: thanks to the gasket, all that remains is to ensure the mechanical strength of the ductwork. There is no need for adhesive tape or mastic. Rivets or self-piercing screws can be used to make accessories and ductwork with gaskets as explained by the manufacturers.

If it is not planned to use accessories with gaskets, it is essential to use a special airtight ventilation adhesive at each junction between ducts, or mastic. Take care also to do as little cutting as possible on site.

Any bushings (through walls, the roof, etc.) must be made with rigid duct.

In order to ensure proper airtightness where ducts pass through walls, we strongly recommend leaving adequate space for the ducts.

The connection between the ventilation units and the duct is one of the most sensitive points with respect to airtightness. In all cases, the junction between the unit and the duct must be airtight.

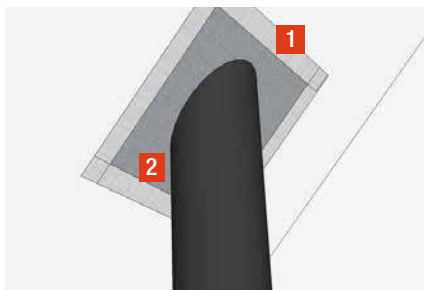

Sealing part for the bushing in a wall giving on the exterior

- 1** Special tighten adhesive
- 2** Metal sheet

We recommend connecting the units to the terminal ducts by means of a coupling, preferably with gaskets, in order to ensure a proper junction between the exhaust unit and the duct. The coupling must be bedded to ensure airtightness between the dwelling and the supporting wall. Failing this, any other system that provides equivalent tightness while nevertheless leaving it possible to remove the device can be considered.

A special component with a metal plate at the wall in contact with the exterior and a special sealant adhesive can be used to ensure the airtightness of the wall bushing.

Recommendations to control the tightness of the roof bushing:

- 1** Roof hoods
- 2** Mastic seal
- 3** Skylight frame
- 4** Bonding with vapour barrier adhesive tape or pose of a sleeve with adhesive tape
- 5** Vapour barrier
- 6** Mastic seal

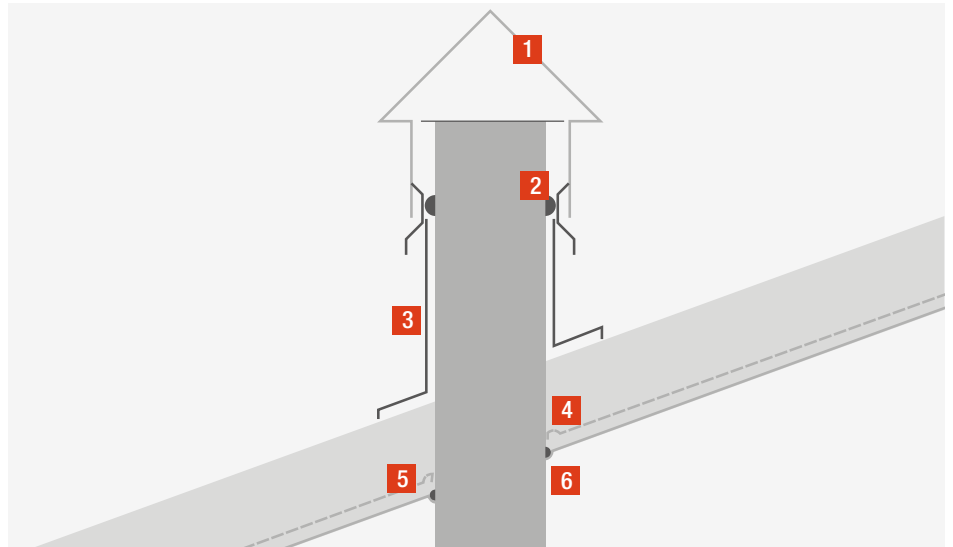

Airtightness of roof outlet

Recommendations to control the tightness of the wall bushing:

- 1** Insulation
- 2** Mastic seal
- 3** Tube

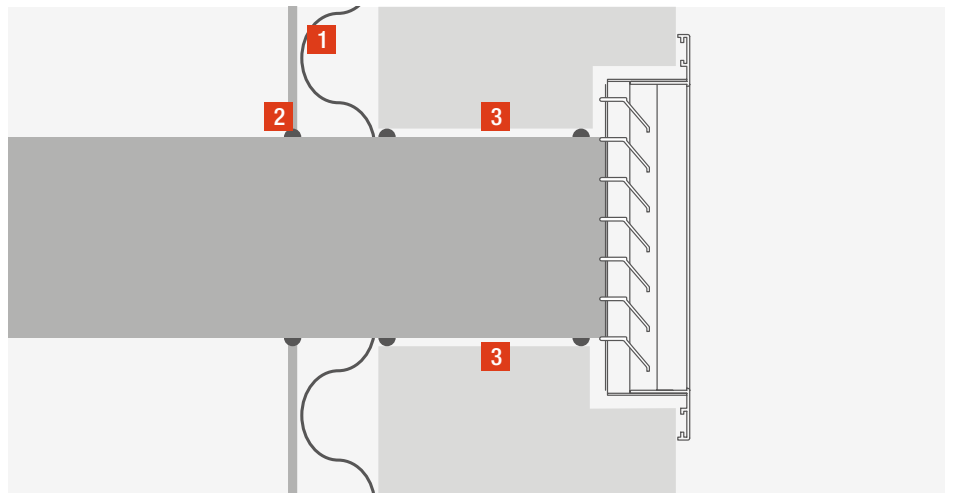

Airtightness of wall-mounted outlet

10. SUPPLY AND EXHAUST UNITS

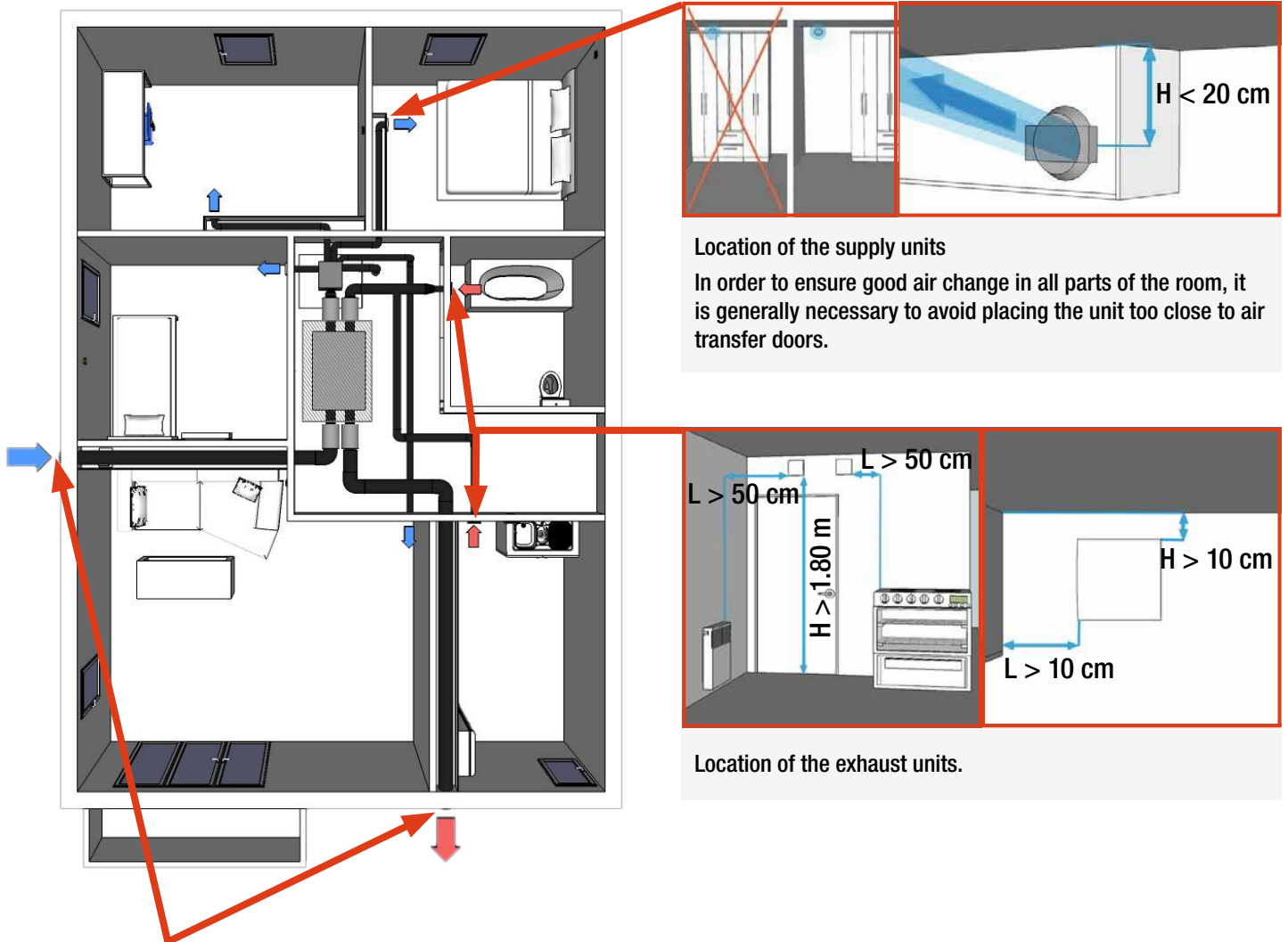

Location of the supply units
 In order to ensure good air change in all parts of the room, it is generally necessary to avoid placing the unit too close to air transfer doors.

Location of the exhaust units.
 $L > 50\text{ cm}$
 $H > 1.80\text{ m}$
 $L > 10\text{ cm}$
 $H > 10\text{ cm}$

Requirement for fresh air inlet / exhaust air outlet grilles:
 · Ø 160 mm
 · less than 20 Pa at 230 m³/h

Units can be wall-mounted or installed in the ceiling; they must be readily accessible for cleaning (supply and exhaust units) and maintenance (replacement of the batteries in particular for the exhaust units).
 Generally speaking, avoid hindering the passage of the air by placing the units behind a cabinet or a household appliance.

 Any duct carrying hot air that is outdoors or in an unheated volume must be insulated with 50 mm of glass wool or equivalent. At supply grilles, airflow must be adjusted by the installer. Desired flow rates may be achieved by the use of foam in the pipe or by the use of manual balancing register.

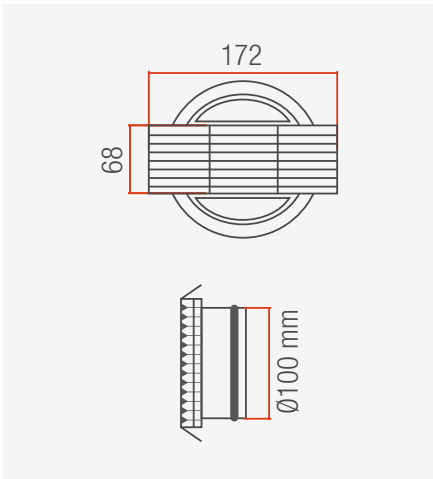

SDC 100 supply unit

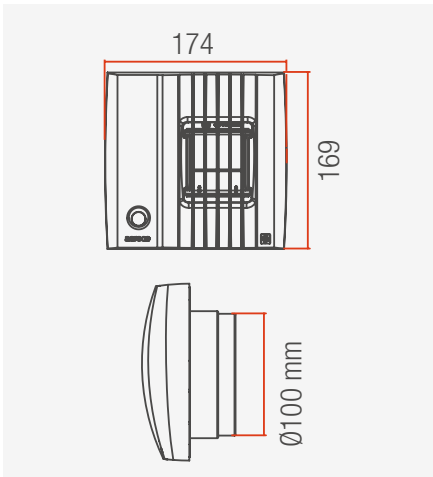

BXC exhaust unit

10.1. SUPPLY GRILLES

For good supply air distribution, it is important that the stream should be able to stick to the wall or ceiling. This requires placing the units less than 20 cm from the ceiling and making sure that the stream of air does not cause discomfort for the occupant (draught, etc.).

In order to ensure good air change in all parts of the room, it is generally necessary to avoid placing the unit too close to doors of the main rooms.

10.2. EXHAUST BXC UNITS

Regarding the BXC exhaust units, we recommend the following positioning: ends not more than 10 cm from the walls and at least 1.80m from the floor. When the units are placed in the ceiling, the same rules can be applied for the distance from the wall (In addition to better aeraulic performance, this distance also allows easier access for measurement, especially when using an airflow cone).

Because cooking, heating appliances give off heat, humidity-controlled units must be placed at least 50 cm from these appliances. The same recommendation has to be followed if the apartment is equipped with air conditioning.

The BXC exhaust unit offers a range of possible airflow settings to meet specific needs, or regulatory requirements. The fixed shutter can be set at one of six positions, with an average step between each setting of + 10 m³/h (maximum = + 50 m³/h). See the table below for more details concerning the airflow set up at 60 Pa.

Ø 100 mm			Ø 125 mm		
Pos.	Min airflow (m ³ /h) @ 60 Pa	Max airflow (m ³ /h) @ 60 Pa	Pos.	Min airflow (m ³ /h) @ 60 Pa	Max airflow (m ³ /h) @ 60 Pa
0	9	62	0	9	54
1	14	70	1	14	62
2	19	77	2	19	70
3	23	85	3	23	77
4	28	93	4	28	85
5	33	101	5	33	93

Case of exhaust units with manual flow control

The installation of a unit with a manual control (switch) must be such that it is easy to trigger the boost flow rate.

All of the manual control devices must be:

- located at a height between 0.90 m and 1.30 m from the floor;
- operable from either a standing or a sitting position;
- located more than 0.40 m from an inside corner or from any other obstacle to the approach of a wheelchair, to allow access by disabled persons.

If the flow is controlled manually by a pull cord, and the unit is directly above a door or window, or a passage, a pull cord take-up device must be provided.

Case of motorized appliances



Individual mechanical devices (such as exhaust hoods, clothes dryers, or isolated motorized exhaust fans) must not be connected to the exhaust duct, whether natural or forced draught.

Case of connected exhaust units: It is possible to add up to 3 exhaust units connected to the DXR Unit (see: § 4.1.Electrical connection on the DXR Unit). If using this type of installation, make sure the exhaust units have the appropriate supply (requires specific transformer code CAL261EX).

10.3. FRESH AIR INLET AND EXHAUST AIR OUTLET

The fresh air intake and the used air discharge must be in direct contact with the outdoor, and not in an attic, garage, or crawl space.

The fresh air intake of the installation must be:

- as far as possible from sources of pollution and air discharges (at least 3m from the ground);
- if possible, on a protected façade.

The exhaust air, for its part, must be far from air intakes (fresh air inlet, doors and windows); it must not be a nuisance for the occupants. If possible, use a different façade from the air intake in order to avoid mixing between the fresh air and the stale air.

We recommend taking the prevailing winds into account, in order to avoid an overpressure in the supply or exhaust duct (discharge up, or horizontal, and favourably oriented with respect to the prevailing winds).

Requirement for fresh air inlet / exhaust air outlet grilles:

- Ø 160 mm
- less than 20 Pa at 230 m³/h



The use of a double used air/fresh air duct is not recommended for this type of installation (Make sure that it avoids the mixing between the intake of fresh air and the discharge of used air).

11. ENVIRONMENTAL CONCERNS

Recycle of electrical and electronic equipment waste at the end of its lifecycle (applicable in the countries of the European Union and other countries with special collection centre).

The symbol on the appliance indicates that this appliance should not be treated as domestic waste. It must be taken to a special collection centre for the recycling of electrical and electronic equipment. For further information on the treatment, recovery and recycling of this product, contact your competent local office, the household waste collection service or the shop where you purchased the appliance.

12. WARRANTY

This guarantee is valid for 2 years from the original date of purchase of your appliance, for faults of the appliance, which have been caused by faulty construction. On these conditions, Aereco guarantee the replacement or the supply of the equipment found to be defective after inspection by its after sales service. In any case, the warranty may not cover additional costs, of labour, transport or compensation of any kind. The warranty does not cover damage due to improper installation in this manual, improper use or attempted repair by unauthorized personnel. In case of problems, please contact your installer or your reseller.



13. CONFORMITY AND STANDARD

The DXR Unit heat recovery system is CE certified. It has also received specific certifications in several countries (available on demand).

The choice of accessories associated with the heat recovery system must comply with the standards in force in the country, and preferably be certified, when such certification exists.

The DXR Unit complies with the following regulatory references:

Directives	Standards
EMC	EN 61000-6-3 : 2007 / A1 : 2011
	EN 61000-6-1 : 2007
	EN 62311 : 2008
Low voltage/LVD	DIN EN 60335-1 (VDE 0700-1):2012-10; EN 60335-1:2012
	DIN EN 60335-2-40 (VDE 0700-40):2010-03
	EN 62233 (VDE 0700-366):2008-11

14. CHARACTERISTICS

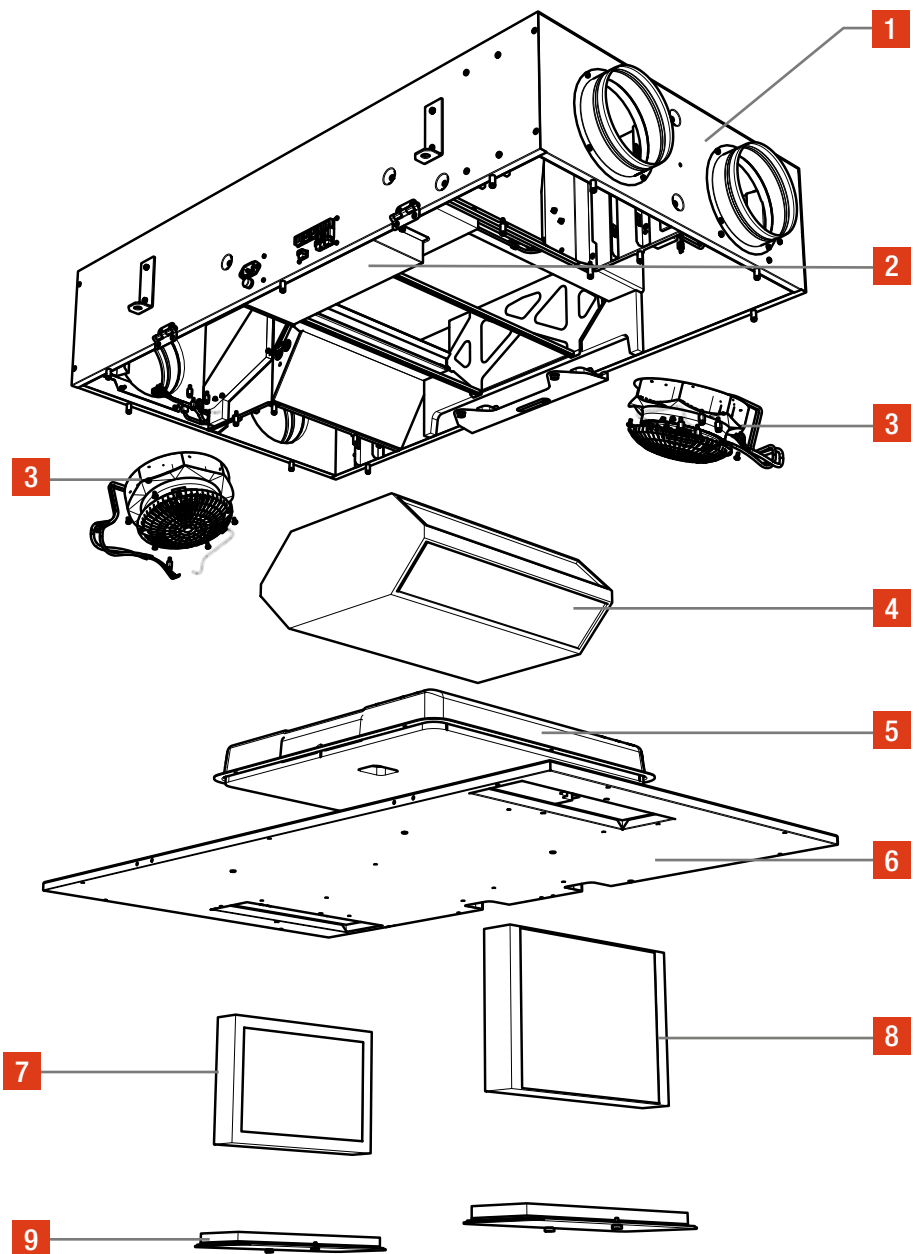

- 1** Base
- 2** Control and supply box
- 3** Fans
- 4** Heat exchanger
- 5** Condensates receiver
- 6** Bottom cover
- 7** G4 filters
- 8** F7 filter
- 9** Access hatches of the filters

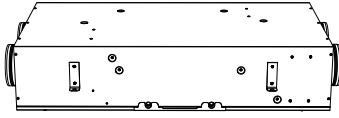

		DXR230
Standard code		DXR
Ecodesign		
Label (EU Ecodesign Directive)		A+
Airflow characteristics		
Max. airflow	m ³ /h	230
Other nominal airflows	m ³ /h	(40) 80 / 140 / 200 / 230 (250)
Constant Pressure @ exhaust set points	Pa	-80 / -100 / -110 / -120
Airflow compensation (filter clogging)		automatic
Airflow balance (supply and exhaust)		automatic
Acoustics		
Sound power level L _w @ 161 m ³ /h, 50 Pa	dB(A)	40
Certifications		CE
Electrics		
Power supply		230 VAC, 50 Hz
Motor type		EC (x2)
Power consumption @ 161 m ³ /h @50 Pa	W	34,2
Power consumption @ 230 m ³ /h @145 Pa	W	91,0
Demand control		
Compatible versions of DX System		EVOLUTION
Min - Max Number of sensors for modulation at exhaust		1 - 5
Exhaust units type		humidity / presence / switch / CO ₂ / VOC
Characteristics		
Exchanger		aluminium / counter flow type / 82% efficiency
Filters		on supply air: 1 x F7 / on exhaust air: 1 x G4
Weight	kg	46
Colour		galva
Material (main)		galvanised steel with phonic and thermal insulation
Dimensions	mm	with duct connectors: 260 x 650 x 1200 / without duct connectors: 260 x 650 x 1160
Installation		
Max. number of main rooms		6
Max. number of technical rooms		5
Connections		2 x (2 x ø160 mm)
Installation		horizontal only, to the ceiling / 4 points of attachment
Other functions		
Interface		Web pages
Bypass		controlled by outdoor temperature / also used for free cooling
Preheating (optional)		with resistance in fresh air ductwork from outside
Condensation management		exhaust through lateral tube / optional condensate pump
Temperature of use		
Installation room		frost free: +5°C < T° < +50°C
Incoming outdoor fresh air or Extract		-5°C < T° < +50°C without preheating / -26°C < T° < +50°C with preheating

DIMENSIONS IN MM : DXR UNIT

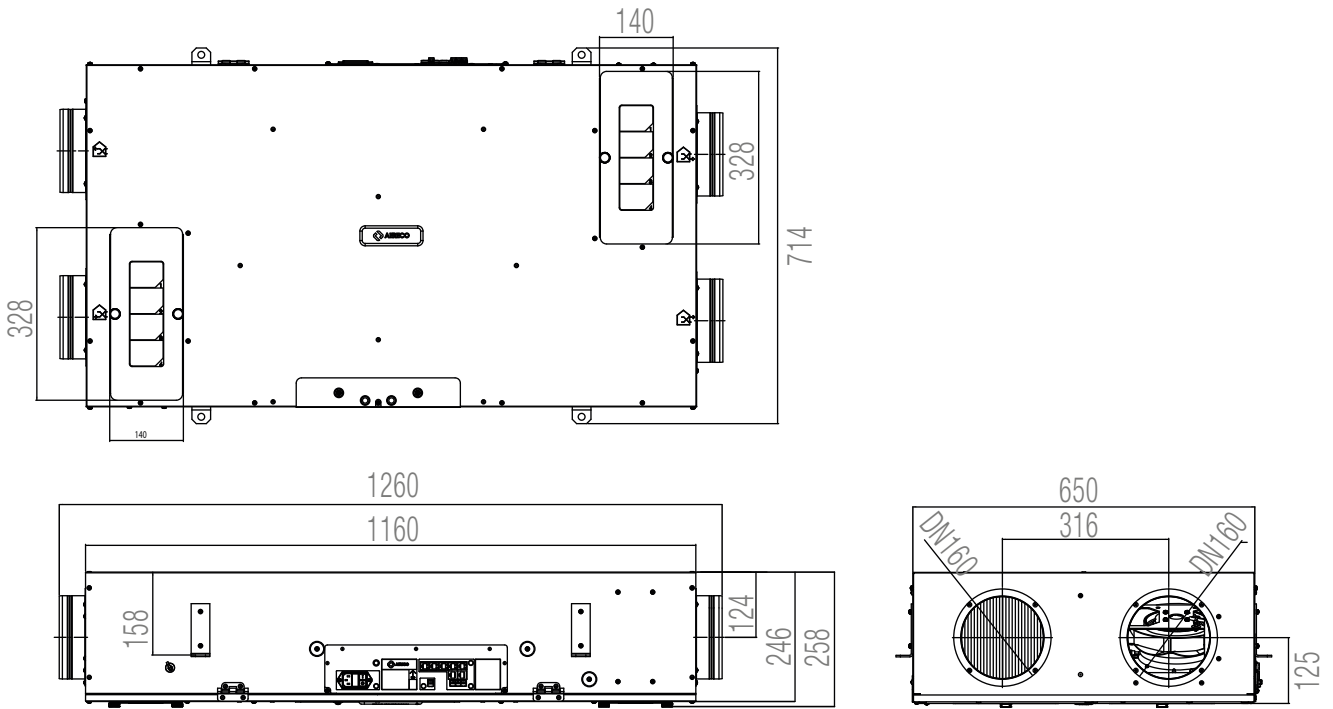

DXR UNIT: AERAUIC CURVES WITH SOUND POWER LEVEL VALUES

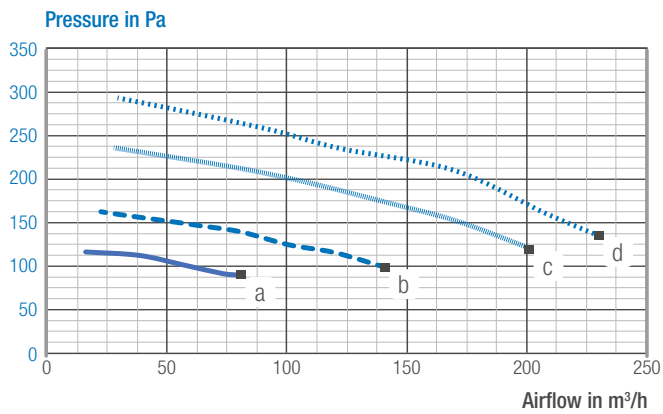

DXR Unit maximal airflow setting :
 — 80 m³/h — 200 m³/h
 - - 140 m³/h ···· 230 m³/h

Sound power level L_{wa}
 a = 40 dB c = 46 dB
 b = 43 dB d = 49 dB

DXR UNIT: POWER CONSUMPTION CURVES

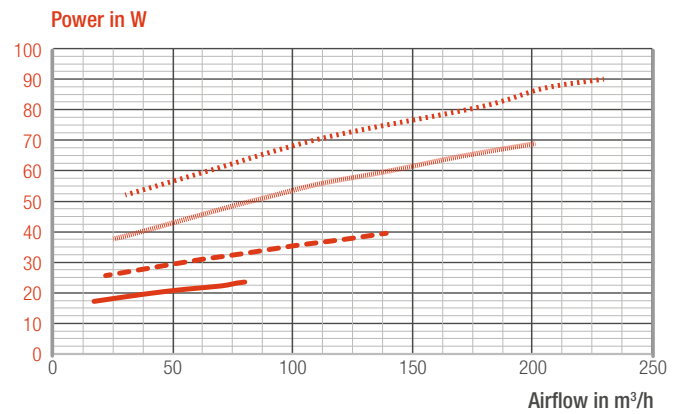

DXR Unit maximal airflow setting :
 — 80 m³/h — 200 m³/h
 - - 140 m³/h ···· 230 m³/h



Aereco S.A.
62 rue de Lamirault
Collégien
77615 MARNE LA VALLEE CEDEX 3
FRANCE
www.aereco.com