

**DX SYSTEM
DXR 230 EXCELLENCE MB****CE**

Heat recovery ventilation for ceiling installation

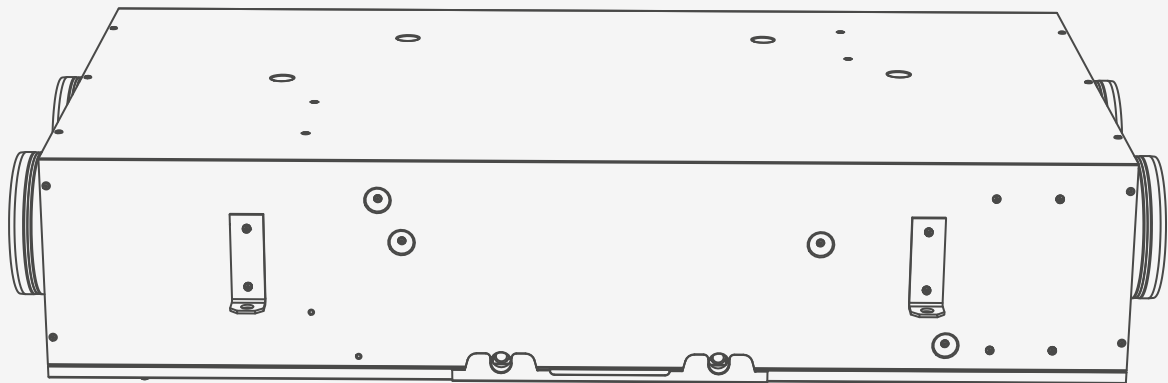

1. Introduction	3
1.1. Warnings	3
1.2. Pictograms	3
2. Description	4
2.1. General information	4
2.2. Construction / Dimensions	6
2.3. DXR Assembling	6
3. Installation	8
3.1. Location of the installation	8
3.2. DXR Unit	8
3.2.1. Location	8
3.2.2. Accessibility	9
3.2.3. Fixing of the DXR Unit	9
3.2.4. Duct connections to the DXR Unit and to the DX Hub	11
3.2.5. Duct connection to the DX Hub 6	12
3.2.5. Evacuation of condensates	12
3.3. Exhaust compensation valve (MPC 125)	13
3.4. Defrosting	14
3.5. Sensors	15
3.5.1. Presence sensors (DX S-PRE)	15
3.6. Smart interface	16
3.7. 2I2O Module	16
3.8. Special care for the ductwork	17
3.9. Fire protection	17
4. Electrical connections	18
4.1. Electrical connection on the DXR Unit	19
4.2. Electrical connection of the defrosting	20
4.3. Electrical connection of the condensate pump	20
5. Starting and settings of the DXR system	21
5.1. Ways to access to the interface	21
5.2. DXR Home page	25
6. First start	29
6.1. Choice of language	29
6.2. Choice of unit of temperature	29
6.3. Date of installation	29
6.4. Determination of the number of sensors connected	30
6.5. Pairing of sensors and supply ducts	30
7. How to bring up to date the versioning	31
8. Maintenance	32
8.1. Regular maintenance of the installation	32
8.2. Power supply and motor material protections	32
8.3. Filters	33
9. Troubleshooting	35
10. Acceptance of works	36
10.1. Visual inspection	36
10.2. Commissioning procedure for aereco DXA modbus excellence	37
10.3. Tests and measurements	38
10.3. Commissioning registration for aereco DX modbus excellence	43
11. Specific recommendations for airtightness and insulation of the installation	46
11.1. Insulation of the installation	47
11.2. Airtightness of the installation	47
12. Supply and exhaust units	49
12.1. Supply units / exhaust grilles	50
12.2. Fresh air inlet and exhaust air outlet	50
13. Environmental concerns	51
14. Warranty	51
15. Conformity and standard	51
16. Characteristics	52

1. INTRODUCTION

This document presents the installation and maintenance schemes for the whole system.

1.1. WARNINGS

PLEASE READ THE FOLLOWING INSTRUCTIONS BEFORE THE INSTALLATION:

In case of non-compliance with advice and warnings contained in this manual, the manufacturer can not be considered responsible for damages to persons or property.

The manual describes how to install, use and maintain correctly the appliance. The only way to ensure the efficiency and longevity of the product is to comply with these requirements.

Do not use this appliance for any applications for which it is not intended.

The system must be installed by experienced contractors, trained in the specificities of the process and having the necessary skills in aerualics and electricity.

The use of gloves to carry on the installation is recommended.

After unpacking the appliance, make sure it is not damaged. Any functional default must be reported to your reseller.

The use of an electrical appliance implies the following fundamental rules:

- Do not touch the appliance with a wet or damp body (hands, feet, etc.).
- This appliance is not intended for use by persons (including children) with reduced physical, sensory or mental capabilities, or lack of experience and knowledge, unless they have been given supervision or instruction concerning use of the appliance by a

person responsible for their safety. To avoid any risk, do not allow them to play with the appliance.

- The electrical installation and electrical connections must be carried out by a qualified technician according to the manufacturer’s instructions and in compliance with the characteristics listed on the nameplate of the unit.
- Before carrying out any operation on the appliance, unplug or disconnect it from the power supply, and ensure it can not be accidentally restored.
- Power cable modification or replacement must only be carried out by qualified personnel or by After-sales Service in order to avoid any accident.
- This appliance can be used by children aged from 8 years and above and persons with reduced physical, sensory or mental capabilities or lack of experience and knowledge if they have been given supervision or instruction concerning use of the appliance in a safe way and understand the hazards involved. Children shall not play with the appliance. Cleaning and user maintenance shall not be made by children without supervision.

1.2. PICTOGRAMS



Warnings
Risks of:
· Appliance damage
· Bad efficiency and longevity of the appliance.



Risk of electric shock.



Electrical component: ground.

2. DESCRIPTION

2.1. GENERAL INFORMATION

The DX System is a range of smart heat recovery ventilation systems that continually supply pollen-free and dust-free preheated fresh air to living areas, ensuring a comfortable feel-good climate.

The DXR is a heat recovery unit with demand-controlled airflows for horizontal installation (in the false ceiling) in the apartment or in the house, from 2 to 5 main rooms, and from 1 to 5 technical rooms (kitchen, bathroom, others wet rooms). The apartment is limited to 2 floors (1 ground floor and 1 floor maximum), and has a maximum surface of 210 m². This HRV system can also be used in offices, hostels, etc., if the required airflow is in accordance with the one offered by the system.

General working of the DX System, Excellence Version

The DX System is comprised of a heat recovery unit (DXR Unit **1**) connected to exhaust and supply ductworks. The counter-flow heat exchanger, integrated into the main unit, ensures the recovery and transfer of most of the energy from the exhaust air to the supply air, thus limiting the energy required to heat the fresh air.

Airflows are automatically controlled according to the needs of each dwelling's room (room-by-room DCV): Outdoor filtered air is supplied **3** in the bedrooms and in the living room. Stale air is extracted **5** from the kitchen, bathroom and WC. On the supply side, the different sensors **4** adjust the airflow room-by-room based on the CO₂ level or based on the presence detection. On the exhaust side, the BXC units adjust automatically the airflow, according to parameters read by various sensors: humidity (used in the kitchen, in the bathroom and in WC), presence (can be used in WC). Versions with switch, presence, remote, CO₂ or VOC sensors can also be used for exhaust units.

At all times, total supply airflows and total exhaust airflows are measured by the heat recovery unit. At all times, these airflows are balanced on the exhaust side an exhaust controlled compensation valve **7** can modulate an additional over-exhaust airflow. This valve can be located in the bathroom or in the kitchen. On the supply side, the hub can modulate an additional over-supply airflow by over opening the pipes'dampers. Exhaust compensation valves is linked to dedicated compensation exhaust unit **6**. The pipes of the hub are linked to dedicated compensation supply unit **3**. The use of an exhaust compensation valve is also a solution to increase the airflows. This scenario is used in order to get a very efficient over-ventilation mode, also called free-cooling mode.

To reach the required supply airflows in each main room (bedrooms or living room), dedicated dampers located in the DX Hub **2** modulate room by room supply airflows according to the information sent by each electronic sensors placed in the main rooms. For example, when the main rooms are occupied, the presence or CO₂ sensors that are located in these rooms send the information to the system to adapt the airflow according to the demand. To reach the required exhaust airflows in each technical room (kitchen, bathroom, WC, ...), dampers located in the exhaust units modulate room by room extract airflows according to the passive or active sensor placed within each exhaust unit.

Supply airflows and exhaust airflows are measured by the use of accurate pressure sensors placed in the heat recovery unit. This allows to calculate with a high accuracy supply and exhaust airflows, without influence of clogging filters or ductwork pressure drop. It ensures the highest efficiency for the system. So that, energy savings are at their maximum.

Specific working of the DXR Excellence version

The Excellence version corresponds to the best HRV solution in terms of indoor air quality and energy savings. In this version, the DX System adapts airflows room-by-room based on specific needs, while balancing supply and exhaust. A distribution box (DX Hub **2**), connected to CO₂ or presence sensors **4** located in all the different main rooms, adjusts supply airflows through dampers. The exhaust airflows are controlled by humidity sensors or presence detectors or other activators in the exhaust units.

Presence detection

The presence sensors located in the main rooms (at least 1 sensor in the main rooms) send the information to the system (presence detected or not) with a timer that depends on the period through luminosity measurement (day or night). This timer keeps the detection at the maximum level during 20 or 45 minutes after the last detection, to optimize the quality of detection. Timer day = 20 min ; Timer night = 45 min. When there is detection, the local supply airflow is increased to ensure the best air quality. If there is no detection, the local supply airflow is reduced to optimize energy savings.

CO₂ detection

Based on the level of CO₂ in the room, a consequence of people occupancy, CO₂ sensors are a really good indicators to modulate the supply airflows and allow reliable measurement of the concentrations of CO₂ in a zone. The analysis principle consists in measuring the absorption of infrared light in order to determine the concentration in a room. This method gives a very accurate response and is not affected by any other pollution (humidity, dust, etc.).

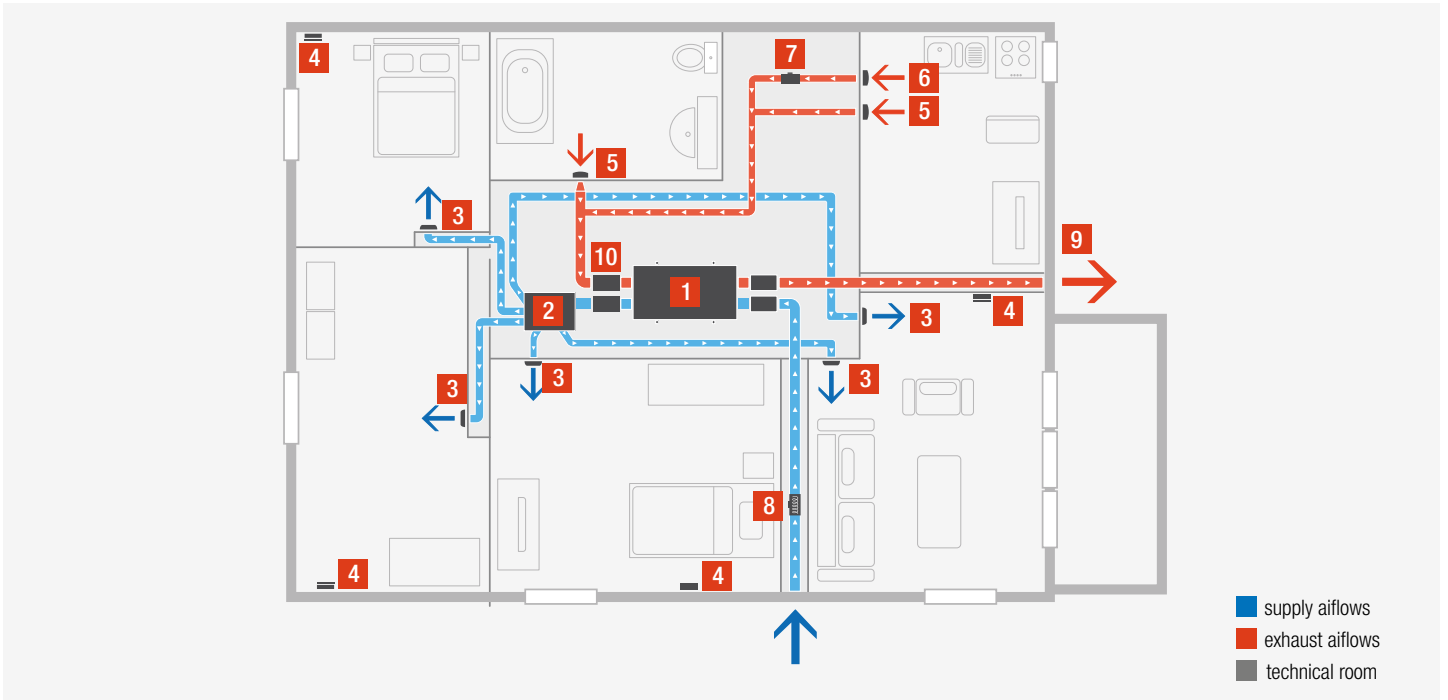

Typical apartment equipped with the DXR Excellence system

1 DXR Unit Heat recovery unit with balanced demand controlled airflows	2 DX Hub 6x100 mm DX Hub 6x75 mm DX Hub 8x75 mm Distribution box for demand controlled supply airflows		
3 SDC 100 Supply unit	4 S-CO2 CO ₂ sensor	S-PRE Presence sensor	5 BXC Exhaust units (various sensors)
6 BXC b Exhaust unit for balance	7 MCP 125 Exhaust compensation valve	8 Preheater Galvanised steel body with built-in resistance	9 Air intake and outlet grilles
10 Acoustic attenuation	RJ 45 cables	Accessories for condensate evacuation	2120 (optional)

List of components

2.2. CONSTRUCTION /DIMENSIONS

DXR Unit 230 m³/h – Heat recovery unit

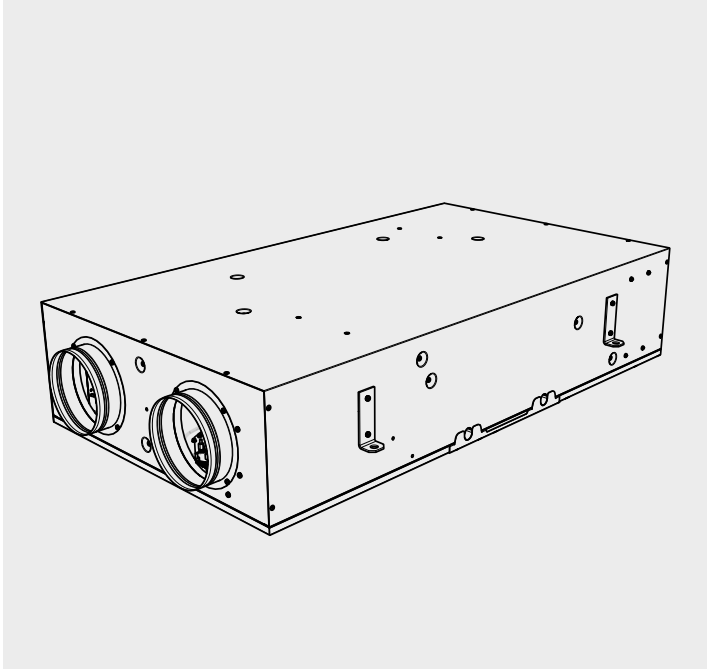

See the characteristics of the DXR Unit system on page 53

- Envelope in galvanised steel, painted in white
- 2 low energy consumption fans driven by EC electronic motors (supply air and exhaust air).
- F7 anti pollen filter for the fresh air.
- Return G4 filters to protect fans and the exchanger.
- Continuously checking of filter clogging, and warning for filter change.
- High efficiency heat exchanger with aluminium plates, washable.
- Intelligent electronic control unit of the heat recovery, with control interface.
- Integrated bypass and free cooling/free warming automatically controlled.
- Flexible duct to drain condensate.

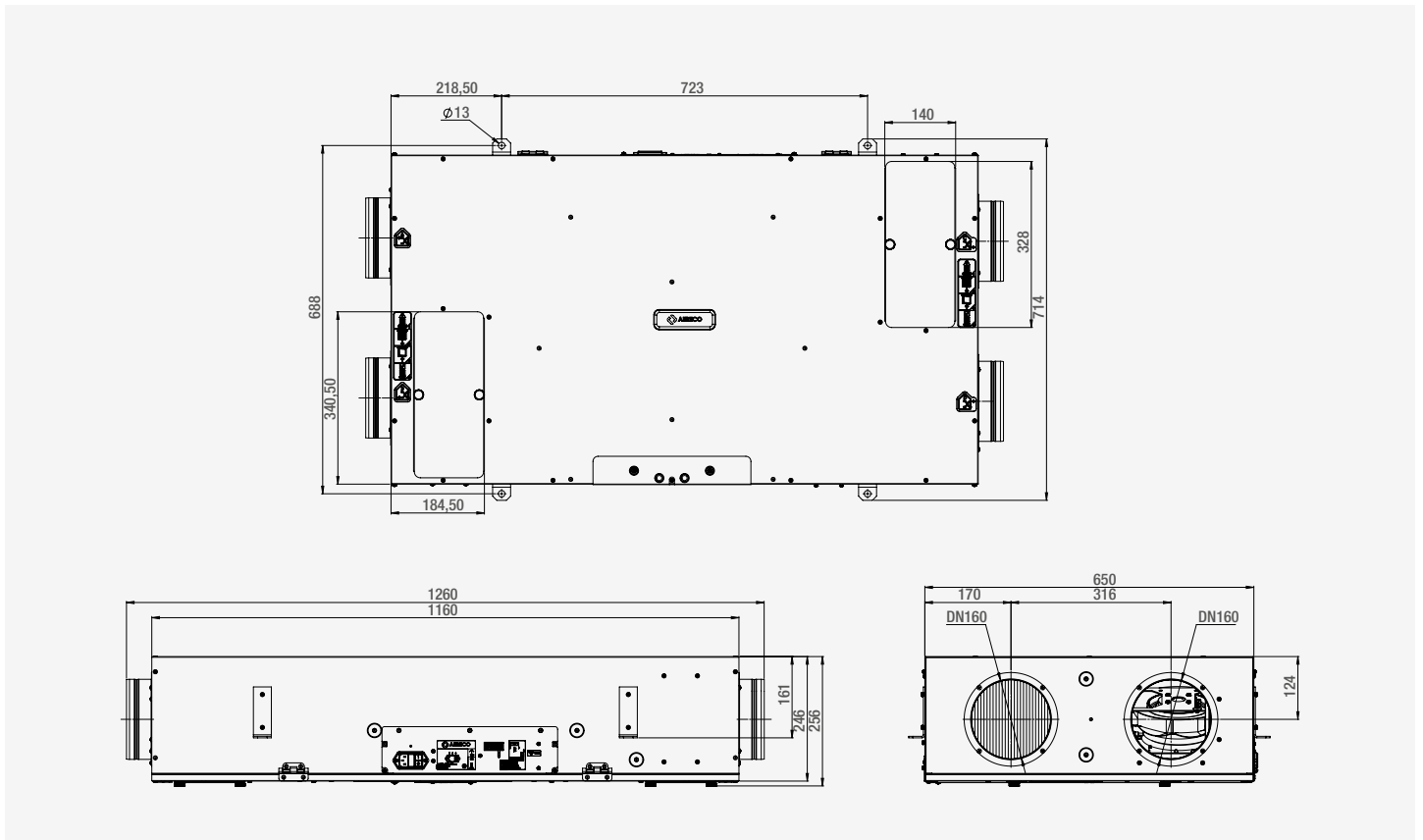

Dimensions of DXR Unit (mm)

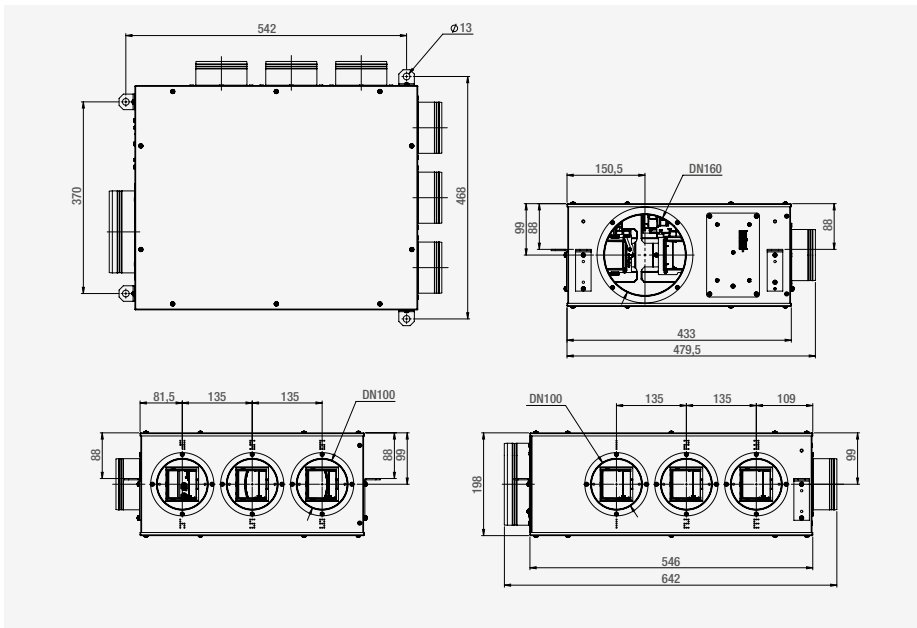

Dimensions of DX Hub 6x100 mm

DX Hub – Distribution box for demand controlled supply airflows

- DX Hub 5 : 5 outlets in DN100 + 1 outlet for balanced airflows in DN125
- DX Hub 6 : 6 outlets in DN75. Outlets n°5 and n°6 are dedicated to living room airflows only and modulate both at the same time according to the living room electronic sensor.
- Envelope in galvanised steel.
- Dampers for supply airflows, driven by sensors (Presence or CO₂) for each room.
- Damper for balanced airflows (specific to DX Hub 5)

The distribution box (DX Hub) coupled to the exhaust compensation valve enables the balance between supply and exhaust airflows.

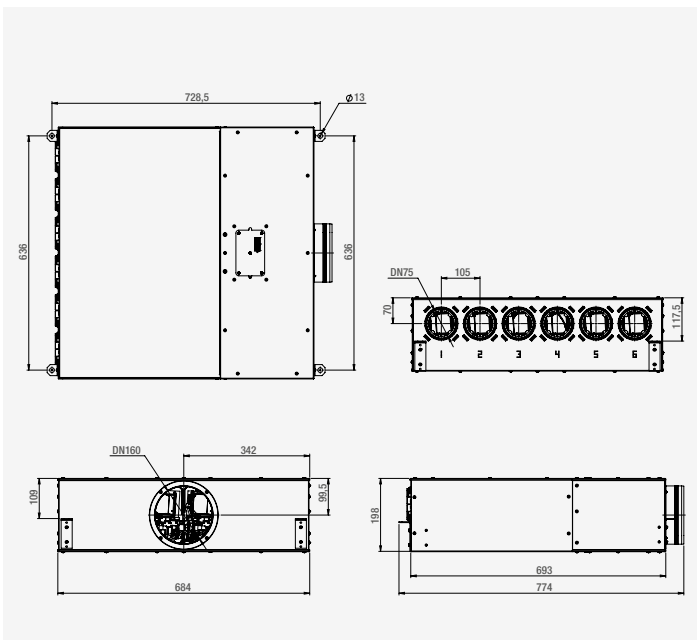

Dimensions of DX Hub 6x75 mm

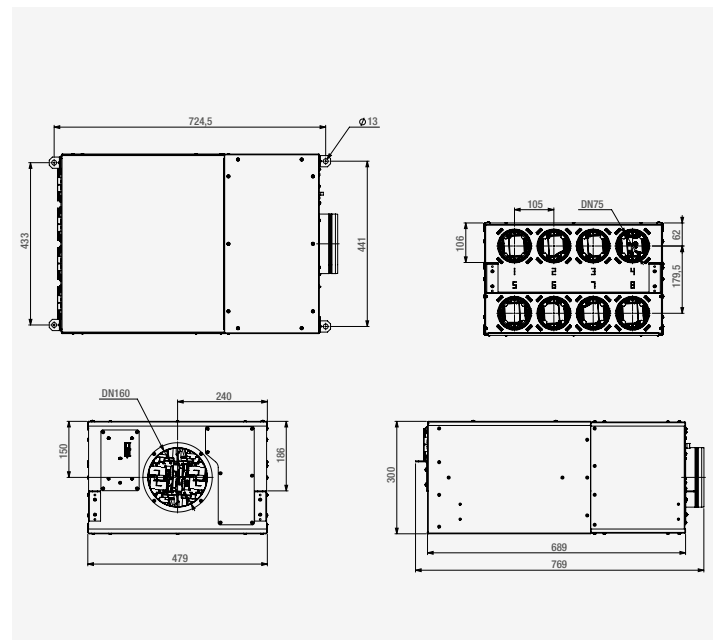

Dimensions of DX Hub 8x75 mm

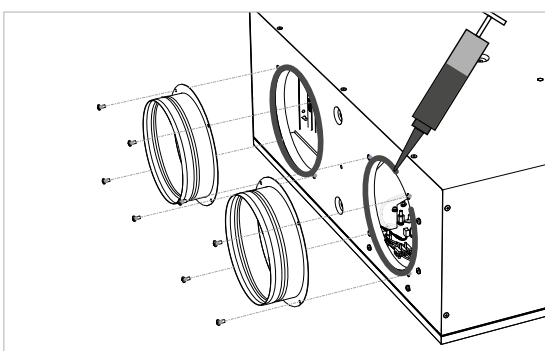

Assembling of the DXR spigots

2.3. DXR ASSEMBLING

When delivered, the DXR unit is furnished with 4 spigots with 4 screws each.

Those 4 spigots have to be screwed and sealed to the DXR unit as indicated on the scheme.

The seal can be made thanks to silicone seal.

Following the seal applied on the DXR Unit, a drying time has to be taken into account before the operability of the DXR.



3. INSTALLATION

3.1. LOCATION OF THE INSTALLATION



The unit must be installed into the heated space, in parts of the dwelling relatively insensitive to noise, not in the unheated space (attic, etc.). Upper and lower temperature limits for the main unit are 5°C and 50°C

Ductwork should be installed in the heated space. If not, they must be insulated with 50 mm minimum of glass wool (or equivalent). The non compliance with these conditions leads to the degradation of the heat recovery performance.

	Features and uses		
	DXR Unit and DX Hub	CO ₂ sensor	Exhaust compensation valve
Max. altitude of the product installation	2000 m	2000 m	2000 m
Temperature range of the installation place	5°C – 50°C	5°C – 40°C	5°C – 40°C
Humidity range of the installation place	5 % - 95 %	Max. 80 % at 31°C, linear decrease up to 50 % at 40°C.	5 % - 95 %

3.2. DXR UNIT AND DX HUB



The caps on the DXR Unit must stay during the entire duration of the work, in order to keep dust and pollution from getting into the boxes.

3.2.1. LOCATION

Before the installation, be sure of the solidity of the ceiling where you plan to install DXR Unit and DX Hub.

- Weight of DXR Unit = 46 kg
- Weight of DX Hub 6x100 = 11 kg
- Weight of DX Hub 6x75 = 19 kg
- Weight of DX Hub 8x75 = 20 kg

The DXR Unit must be attached so that the gap between the ceiling and the top of the unit is at least 10 mm, and positioned exactly horizontally (max 1° tolerance).



The non compliance to this requirement may lead to serious problems of condensate evacuation.

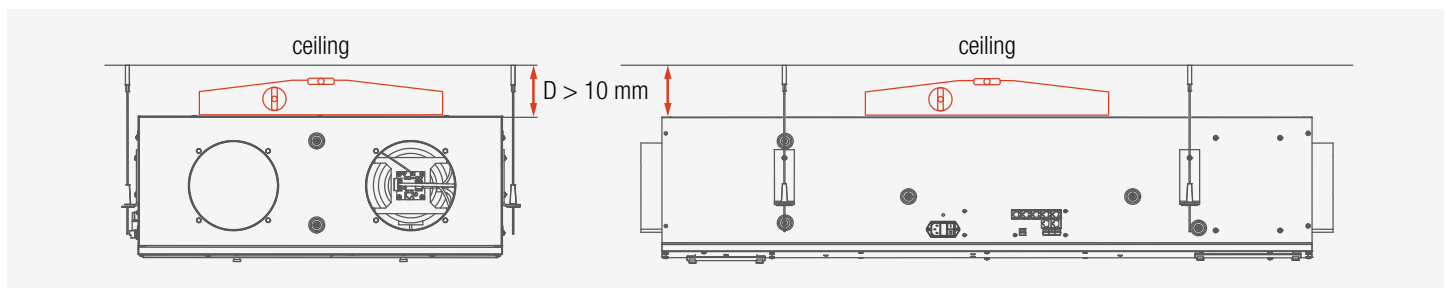

Positioning of the DXR Unit



When mouting the DX Hub, the top must be closed, otherwise the Hub may wrap.

3.2.2. ACCESSIBILITY



The DXR Unit, as well as the distribution box, must be positioned so that it is accessible for the maintenance and in case of access or removal from the false ceiling.

For easy maintenance, leave an access hatch in the false ceiling in order, to have ready access to the hatches of the filters, located under the DXR Unit. The inspection hatch must also be dimensioned so that the DXR Unit can be removed from the false ceiling.

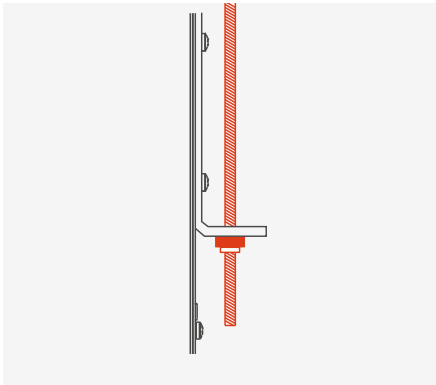

Example of studs

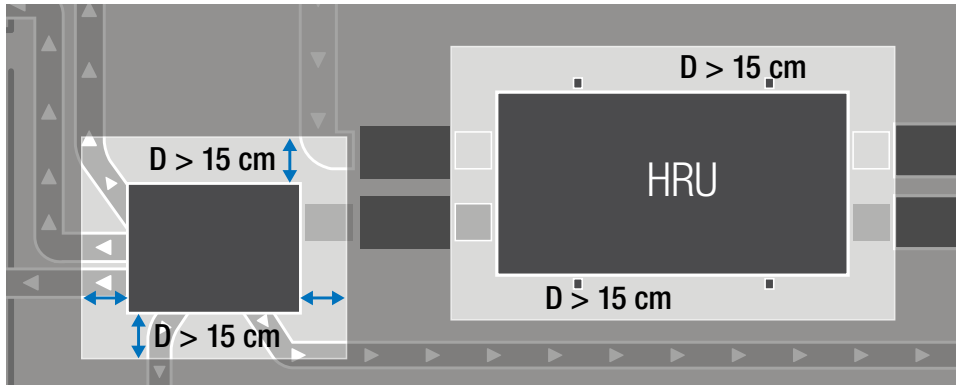

Recommendation for access hatches

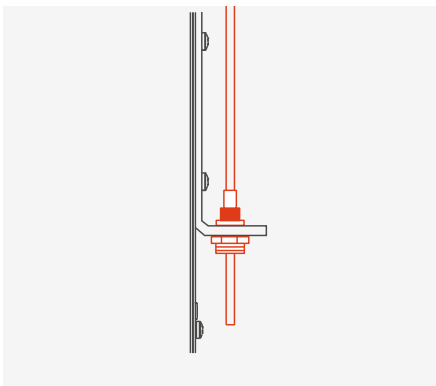

Example of flexible type attachment with auto-blocking system

The electrical connections must be easily accessible to be able to disconnect the DXR Unit from the supply before any operation on the appliance. The circuit-breaker must be easily identified and accessible.

Recommendation: leave an extra 15 cm space around the product to facilitate handling. An extra upper or lower space of 2 cm is also recommended.

3.2.3. FIXING OF THE DXR UNIT

The DXR Unit and the DX Hub each have 4 brackets for direct fixing to the ceiling, above the false ceiling. Using studs or cables to attach the box facilitates precise observance of the positioning requirements.

The DX Hub can be either installed vertically or horizontally.



The auto-blocking fixation system proposed by Aereco can only be used with a concrete ceiling

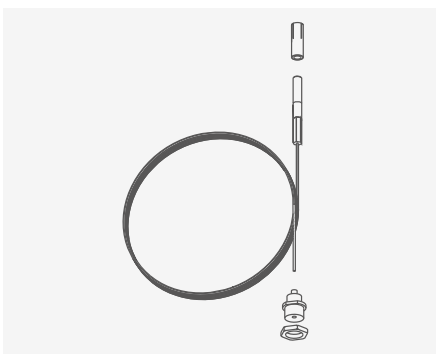

Quick suspension with auto-blocking system proposed by Aereco

The DXR Unit has 4 brackets for direct fixing to the ceiling, above the false ceiling. When installed on the ceiling, using studs or cables to attach the DXR facilitates precise observance of the positioning requirements.

The auto-blocking fixation system proposed by Aereco can only be used with a concrete ceiling.

Quick suspension with auto-blocking system proposed by Aereco for the DX Unit (optional, code : ADX1106)

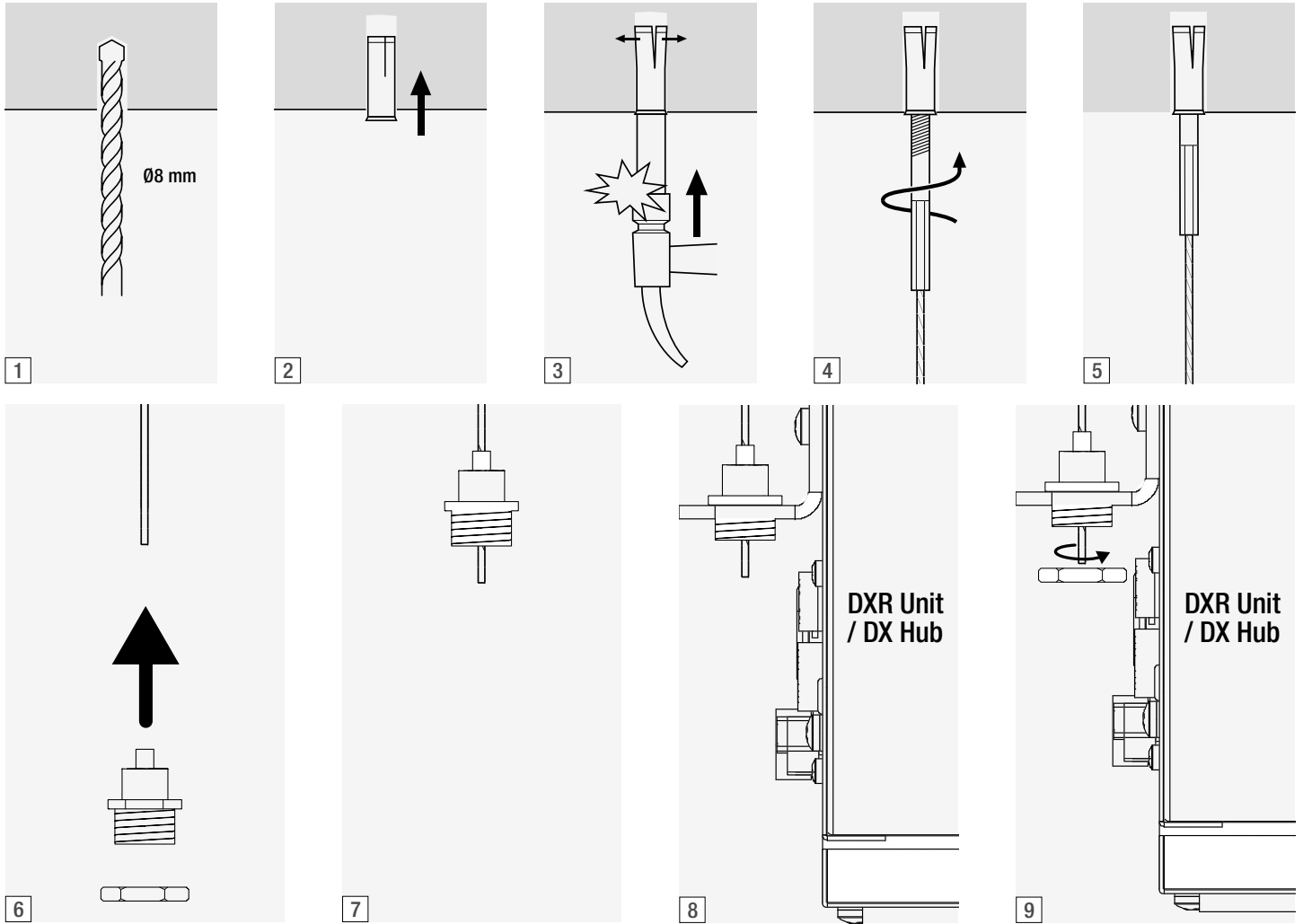

Installation of the quick suspension system

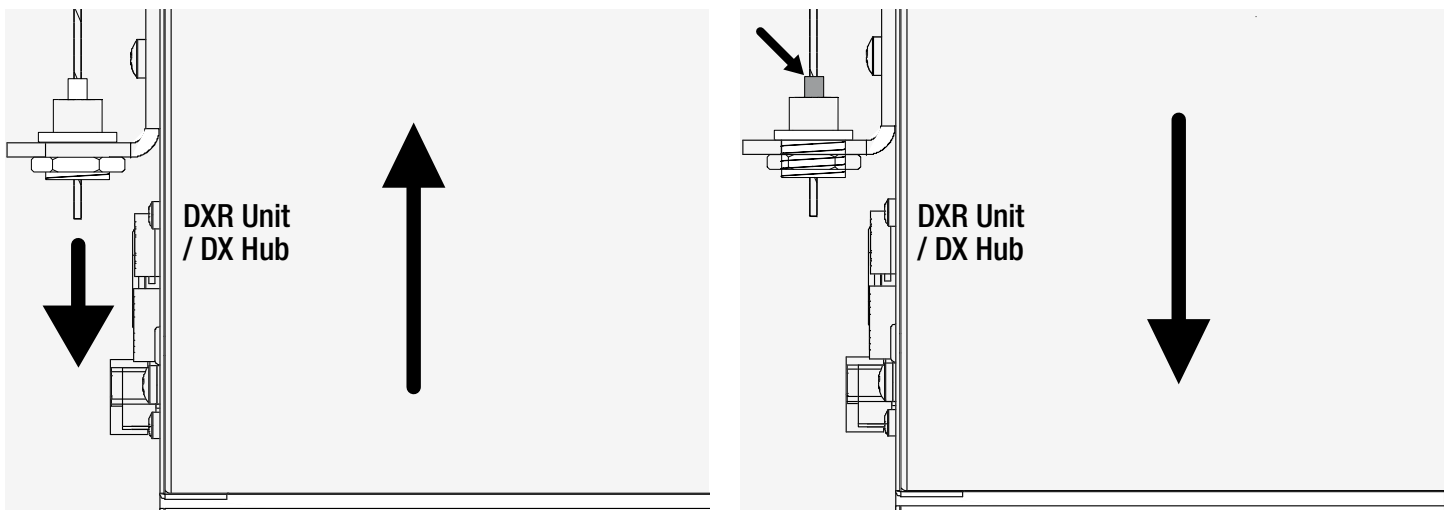

To pull up the DXR: pull the cable downwards

To bring down the DXR: push the top part of the fixation

3.2.4. DUCT CONNECTIONS TO THE DXR UNIT AND TO THE DX HUB

The connections to the DXR Unit are all in Ø160 mm. Labels on the unit identify the 4 ducts to be connected (fresh air, used air, supply air, exhaust air). **Outdoor fresh air and used air ducts must be insulated.**



Be careful to respect top and bottom of the installation.

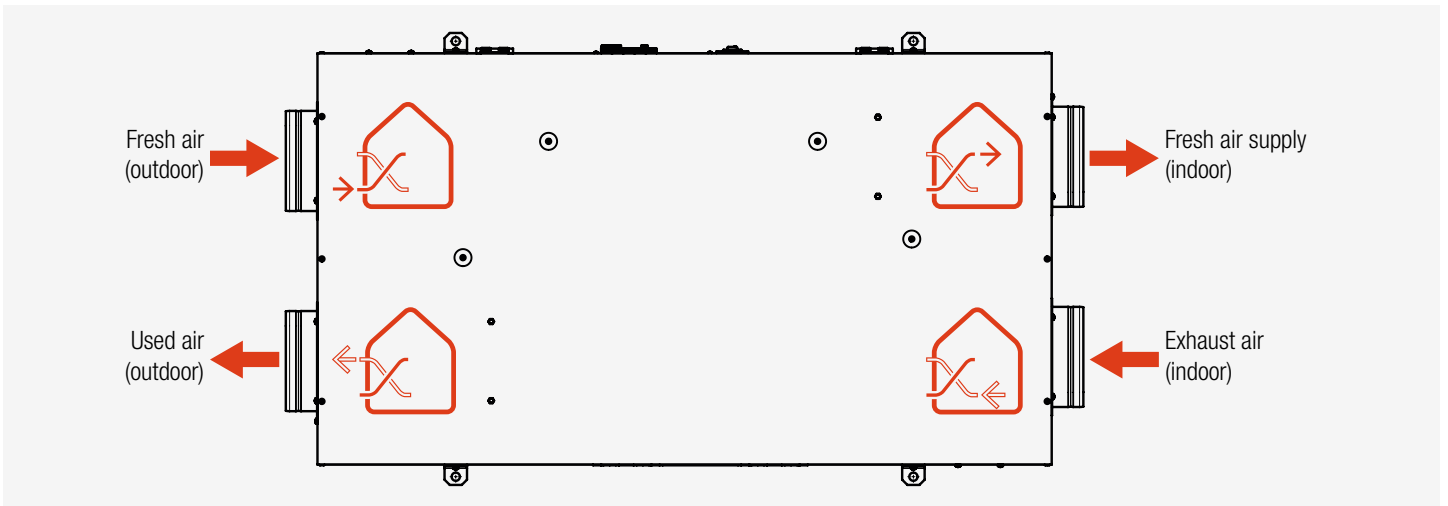

Labels on the unit identify the 4 ducts to be connected (fresh air, used air, supply air, exhaust air).

- Supply:** rigid or semi-rigid duct
+ flexible connection to the unit (1 m max) (avoid noise in the room)
- Exhaust air:** rigid (avoid pressure drop) or semi-rigid duct
- Air intake and air outlet:** insulated rigid duct (avoid pressure drop and condensation)



All supply grilles have to be balanced to reach the required airflow in each main rooms (living room, bedrooms...). This may be done by the use of manual registers, blocks of foam, or grilles with nuts inside allowing to adjust room by room supply airflows in each main room.

All exhaust grilles have to be balanced to reach the required airflow in each wet room (kitchen, rest room, bathroom...). This may be done by the use of manual registers, blocks of foam, or grilles with nuts inside allowing to adjust room by room exhaust airflows in each wet room.

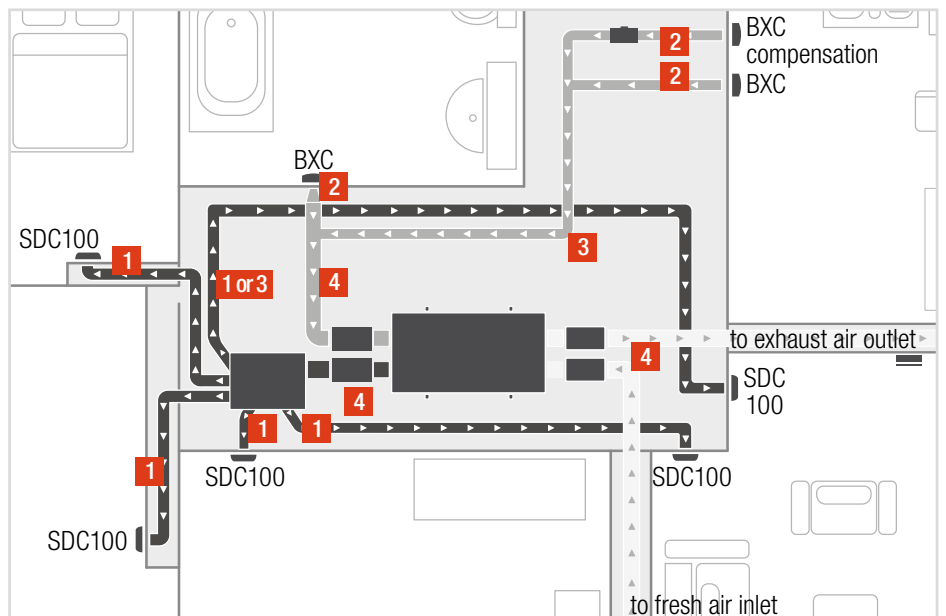

Duct diameters and recommendation concerning the type of ducts

- 1 Ø100 or Ø75 mm
- 2 Ø100 mm or Ø125 mm
- 3 Ø160 mm
- 4 Ø160 + 50 mm insulation

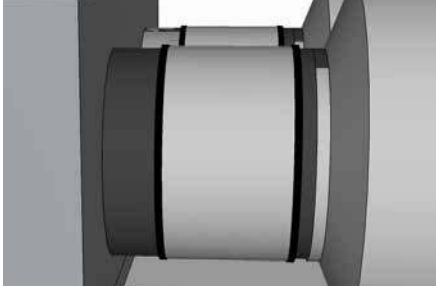

Connection with flexible sleeve

- If rigid ducts are used, the connection between the DXR Unit and the duct must be made using a flexible sleeve (Ø160 mm), in order to avoid transmitting vibrations from the fan to the duct.
 - Make sure that the flexible sleeve is not twisted or wrinkled and that it is correctly aligned but not completely taut between the unit and the ductwork. To achieve this, it is essential to have a constant section on either side of the sleeve.
 - To perform its function of decoupling between the components, the sleeve can be attached by means of flat metallic clamping rings. It will then be necessary to make sure of the airtightness of the assembly.
- If flexible ducts are used, the connection can be carried on directly to the unit, making sure that the connection is secure and tight with flat clamping rings and adhesive.



In order to fully guarantee the acoustic quality of the installation, it is necessary to attenuate airborne noise from the main unit by:

- 20 dB at 500 Hz at supply
- 15 dB at 500 Hz at exhaust

This can be done using a silencer or an equivalent length of acoustic duct between the DXR Unit and the DX Hub.

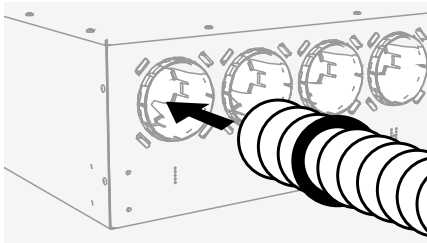

3.2.5. DUCT CONNECTION TO THE DX HUB 6

To connect semi-rigid ducts to the DX Hub 6, it is necessary to add a foam joint (supplied with the DX Hub 6) on the 3rd groove.

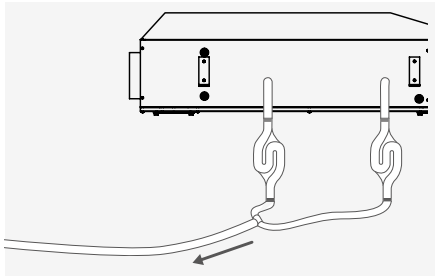

Evacuation of condensates with two siphons

3.2.6. EVACUATION OF CONDENSATES

Condensates must be evacuated to wastewater. This evacuation must be insulated if installed outside the heated volume (risk of freezing). It can be done by gravity with two siphons at the low point, or using a lift pump like the one in the air conditioning unit.

Using a siphon

- Connect the evacuation pipe to wastewater.
- Before first starting up, fill siphons with water.
- Siphons must always be filled with water.

A slope of about 3° is recommended for the good evacuation of condensates. In any case, manufacturer instructions must be followed. The evacuation pipe connection is in Ø16 mm.



The condensate ducts must not be higher than the DXR evacuation outlets.

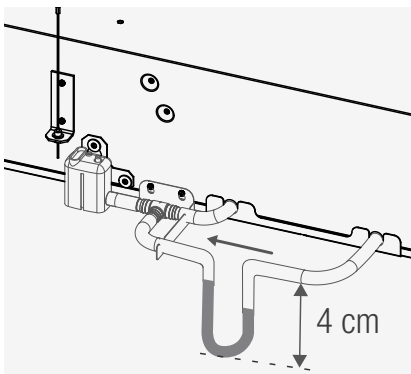

Evacuation of condensates with a lift pump (specific to Aereco)

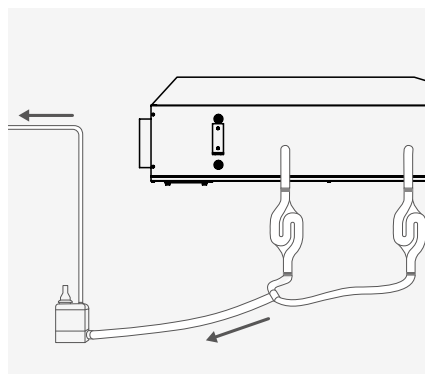

Using a lift pump

- Connect the condensate pump to the DXR thanks to the metal pieces supplied in the condensate kit.
- Connect the pipes using the metal sheet.
- A vertical height of 8 meters must not exceed between the lift pump and the evacuation duct.

Note: The lift pump proposed by Aereco was tested and validated specially for the DX System. Using another lift pump can lead to serious problems of functioning and degrade the security of the system.
The lift pump connection is in Ø6 mm ID.

All the connections must be watertight.

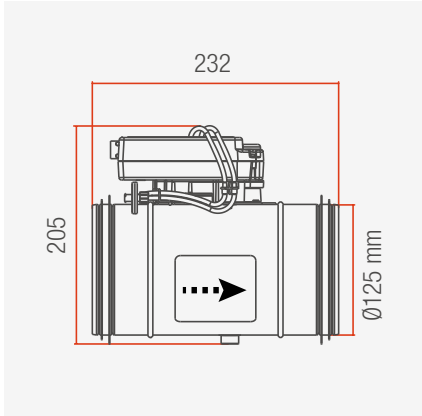

Exhaust compensation valve

3.3. EXHAUST COMPENSATION VALVE (MCP 125)

The valve is located in the final duct that serves the exhaust compensation unit (in the kitchen). It is therefore in Ø125 mm. This product is specific to Aereco system.

The valve can be positioned in any direction, the maximum length being 232 mm. **However, attention must be paid to the direction of the airflow in the valve:** an arrow marked on the valve indicates the correct position.



Check the good quality of the pressure pipe before carrying the installation. The pressure pipe must not be crushed.

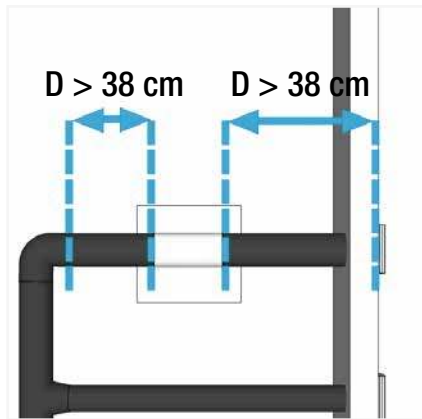

Positioning of the exhaust compensation valve with access hatch

The valve must be placed in the duct, at a minimum distance equivalent to 3 diameters (38 cm for a 125 mm duct) from any fittings, and from the compensation unit.

In addition, there must be an inspection hatch to access the valve for maintenance.

3.4. DEFROSTING

The defrosting is located in the duct that serves the fresh air inlet, upstream from the DXR Unit. It is therefore in Ø160 mm and insulated. **A length of 1 m must be respected between the DXR Unit and the defrosting. The fresh air supply air duct must be manufactured from non-flammable materials (A1 Class according to EN 13501-1).**



The air must travel in the direction shown by the arrows marked on the defrosting device.

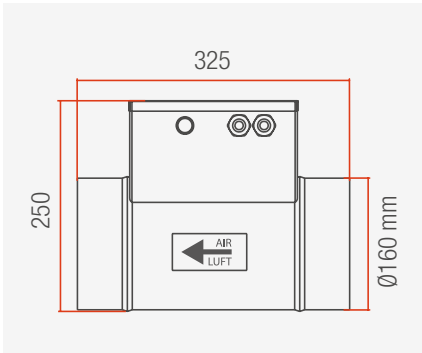

View of the defrosting

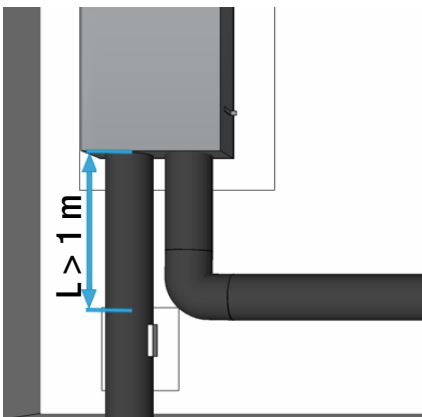

Positioning of the defrosting compared to the DXR Unit

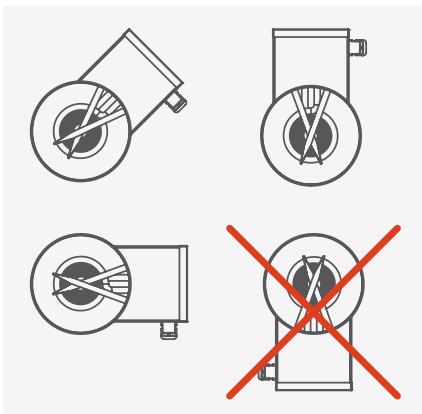

The defrosting must not be installed with the electrical device at the bottom.

The defrosting must be located at a distance of at least twice the connection diameter from a duct bend or external grille, and at 1 m from the DXR Unit. We recommend tilting the duct slightly towards the exterior in order to keep rain water from getting into the defrosting.

The installation must allow access to the defrosting for a manual reset, or for maintenance (access hatch).

Manual reset of the defrosting:

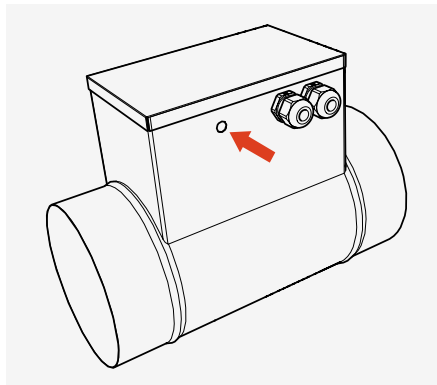

1. Unscrew the black cap

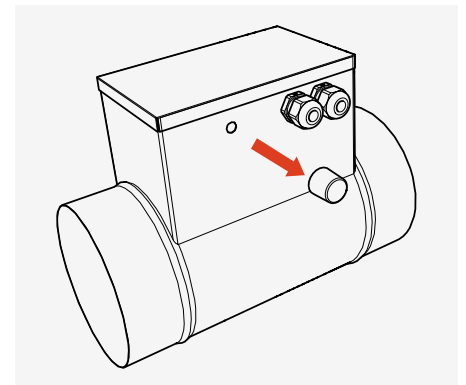

2. Push the red button and screw back the black cap on

Note:

- The DXR Unit has been specially designed to work with the defrosting provided by Aereco (defrost strategy specific to the DX System, and adapted diameter). Besides, it has been CEM certified with the DXR Unit.
- Using another defrosting can lead to serious problems of functioning and degrade the security of the system.

Anti-frost without pre-heating resistance

- When using the DXR Unit without the additional resistance pre-heating, the anti-frost strategy is based on the supply airflow regulation. The supply air fan is switched off and the extract air fan remains active, in order to warm up the heat exchanger.

Be careful, very often, this type of strategy does not comply with an open fireplace. Make sure that you comply with the standard in force in the country of installation.

When the optional defrosting device is used, this anti-frost strategy is not active anymore.

A 1200W preheater allows to warm 200 m³/h @ -20°C. If T° can fall down below -20°C, 2 x 1200W preheaters may be implemented on the same supply duct network. These 2 preheaters can be driven with only one 2120 module. In this situation, the amount power of the 2 preheaters is 2400W, so this value has to be entered in the manufacturer access web page (MAINTENANCE / MANUFACTURER ACCESS / Preheater power).

3.5. SENSORS

The DXR Excellence version is compatible with two types of sensors for the management of supply airflow: presence detection or CO₂.

We recommend to use one sensor per main room (living room and bedroom).

- Presence sensors and CO₂ sensors can be mixed together.
- A maximum of 6 sensors can be connected to the system with Hub 6x100 or Hub 6x75 mm.
- A maximum of 8 sensors can be connected to the system with Hub 8x75 mm.
- The connection to the system is made through RJ45 wires. Only the specific ones supplied by Aereco can be used.

3.5.1. PRESENCE SENSORS (DX S-PRE)

The DX S-PRE presence detector uses infrared radiation to measure movements made in a room.

The detector includes a LED indicator that displays the detections in order to inform the users. When luminosity in the room is very low, the LED is automatically switched off.

The S-PRE sensor must be installed on the ceiling at a place it can easily detect the presence. The operating scenarios are the following ones :

- if detection during the night, over ventilation for 45 minutes after the last detection.
- if detection during the day, over ventilation for 20 minutes after the last detection.
- if no detection, supply airflow is reduced to a minimum to save energy.

The sensor can be fixed in a hole of diameter 62 to 70 millimeters. They are equipped with claws for installation in false ceiling. Location of sensors :

- ceiling positioning
- in a detection zone = zone located at least at 1 meter from walls (considered as zone "where there are few movements")
- height installation ceiling position: up to 3.5 meters.

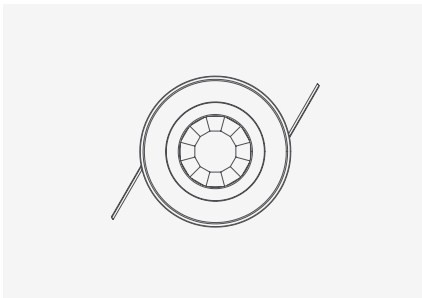

Presence sensor

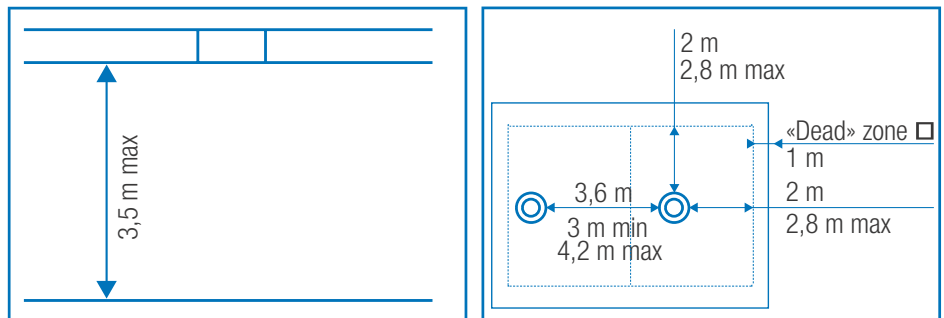

3.6. SMART INTERFACE

As an optional component, a smart interface may be implemented on the bus network. The smart interface allows to enable the automatic mode, the absence mode, or the overventilation mode. The smart interface provides information regarding filters clogging rate and warning messages.

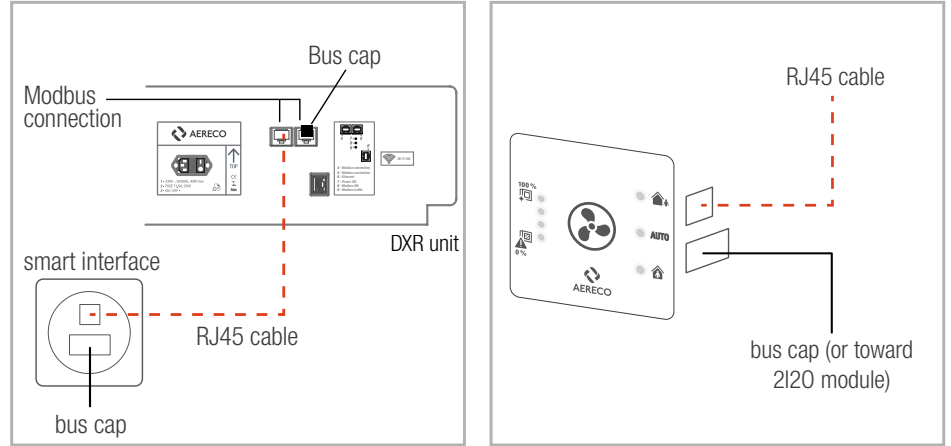

3.7. 2I20 MODULE

- The 2I20 module may be used to display pump warning message on the interface (optional)
- The 2I20 module is mandatory to drive 1 or 2 preheaters
- Only one 2I20 module can be connected on both a pump and 1 or 2 preheater.

Note : On the DXR unit, the RJ45 cable use to link the 2I20 module may be plug into any Modbus connection outlet (up to the installer).

If the 2I20 module is not linked with another module (smart interface for example), a Modbus cap must be plug in the second RJ45 outlet of the 2I20 module.

Pump (2I20 optional) only to display an error message if the pump is not OK

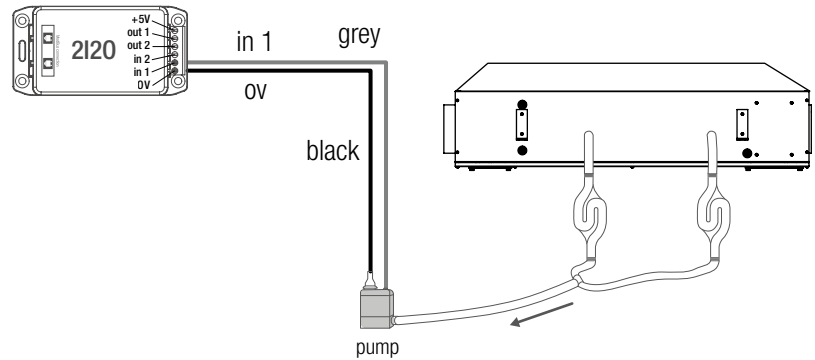

Preheater (mandatory to drive 1 or 2 preheaters)

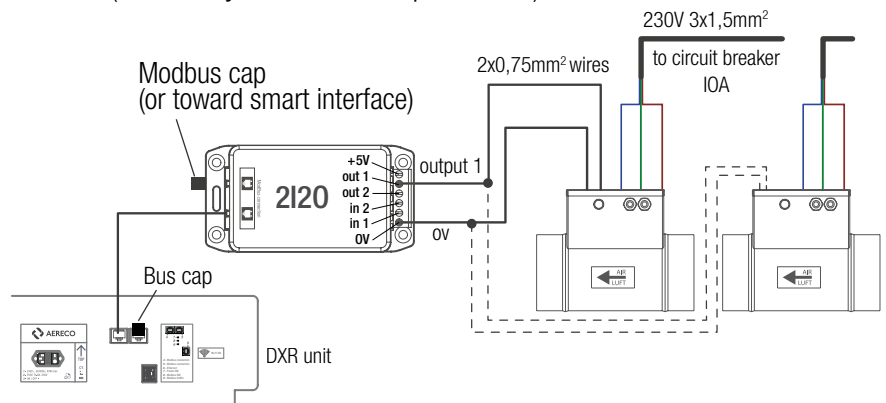

3.8. SPECIAL CARE FOR THE DUCTWORK

Any duct that is outdoors or in an unheated volume must be insulated with 50 mm of glass wool or equivalent. In countries where the temperature can go under -10°C, the recommendation of insulation is at least 100 mm of glass wool.



Mounting of ducts:

- The ductwork must be airtight (see recommendations for an airtight ductwork in page 46).
- Take care not to use a material that is too fragile or too flexible.
- The inner surfaces of all ducts must be as smooth as possible.
- Avoid having too many bends (make them gradual, with a large curvature).
- If using flexible duc:
 - Avoid slopes (flexible ducts must be securely attached).
 - Tauten the straight parts so that the duct is smooth and straight (when using flexible or semi flexible ducts).
 - If the flexible duct is longer than necessary, it must be cut rather than pushing the surplus into the false ceiling.
 - Do not crush the duct or squeeze it down to force it through a narrow passage.
- The interior of the ductwork must be protected during the entire duration of the work (from dust, pollutants, etc.), using caps, plastic bags, or tape.



The installation of supply and exhaust units, and fresh air inlet and exhaust air outlet must be carried out in order to obtain a system that performs well in terms of both aeraulics and thermal and acoustic comfort (see recommendations for the installation of the units in page 46).

3.9. FIRE PROTECTION

The installation must comply with the fire protection standards in force in the country concerned.

4. ELECTRICAL CONNECTIONS



Disconnect the electrical supply before any operations and ensure that the DXR Unit cannot be started accidentally.

A	DXR Unit
B	Smart interface
C	2I2O module
D	Defrosting
E	Lift pump
F	Compensation valve at exhaust
G	Sensors
H	Hub

---	RJ 45
----	Supply (230 V): 1.5 mm ² .

Note: RJ45 cables provide both supply and connections.

Only cables provided by Aereco must be used to carry on the DXR Unit installation. If using different cables, Aereco won't be able to guarantee the good functioning of the appliance.

The installation must be carried out by a professional in compliance with applicable regulations in force in the country of installation. Each product or component used in the installation must also comply with standards in force in the country.

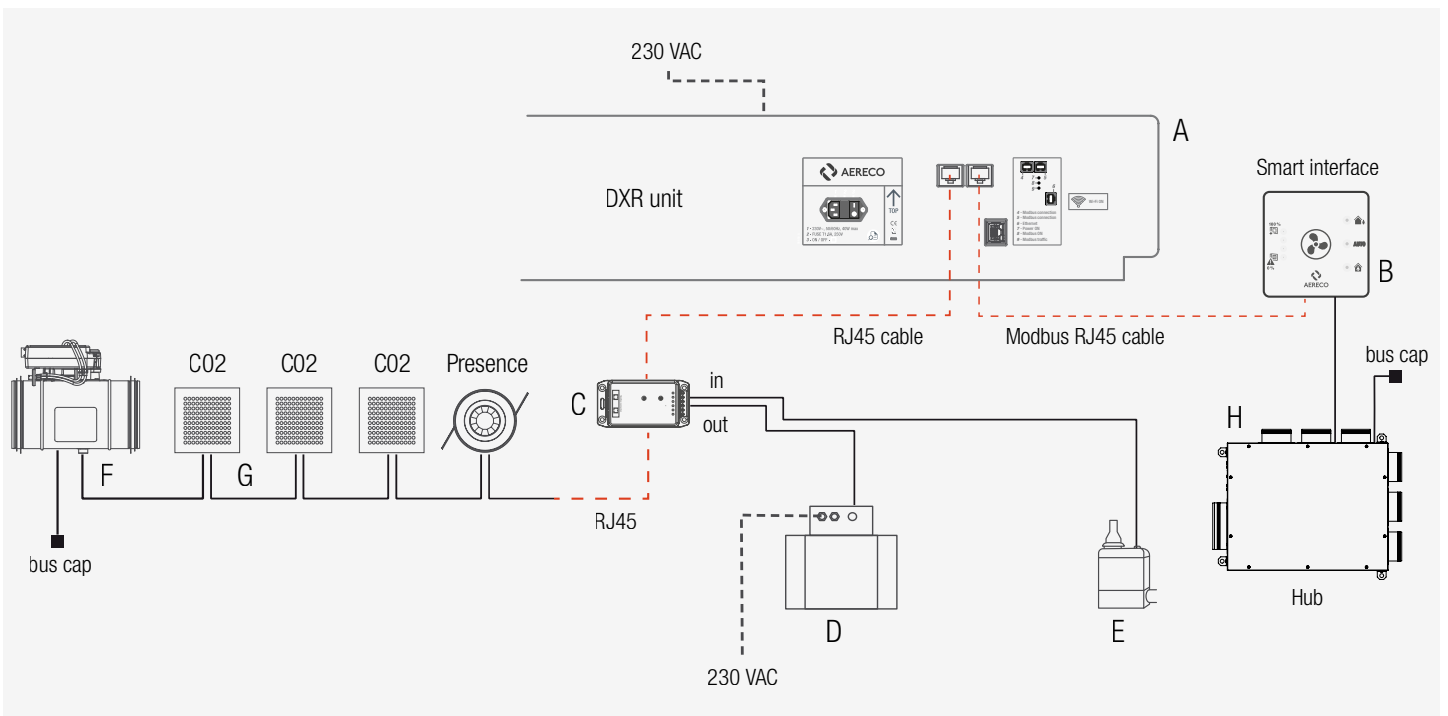

RJ45 maximal length: loop = 100m



ModBus components (2I2O module or smart interface) may be connected on one of the 2 RJ45 ModBus socket (the one you want, it doesn't matter) for a parallel wiring. But the ModBus components may also be connected one after the other for a serial wiring, up to you.

Each modbus line must be ended with a ModBus cap. So, 2 ModBus caps must be connected on the ModBus network (because 2 RJ45 ModBus sockets on the main electronic board).

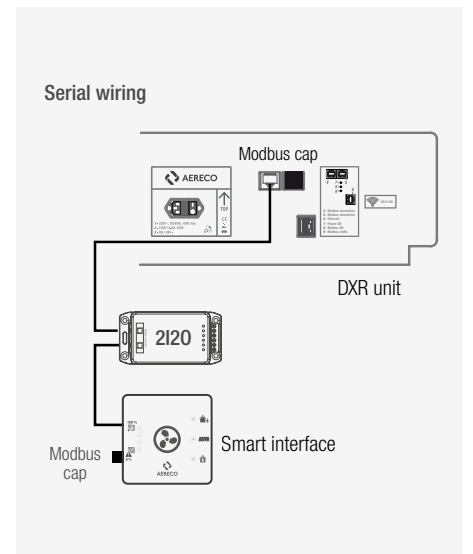
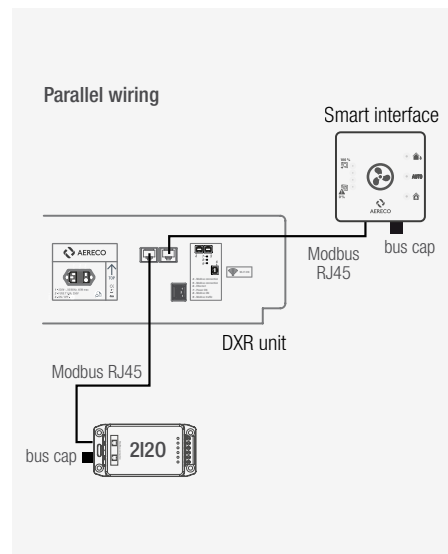

Note: It's possible to connect the smart interface and the 2I2O module with a parallel or a serial wiring.

4.1. ELECTRICAL CONNECTION ON THE DXR UNIT

1	DX ModBus (RJ 45)
2	Ethernet
3	230VAC, 50/60Hz, 180W max
4	ON / OFF

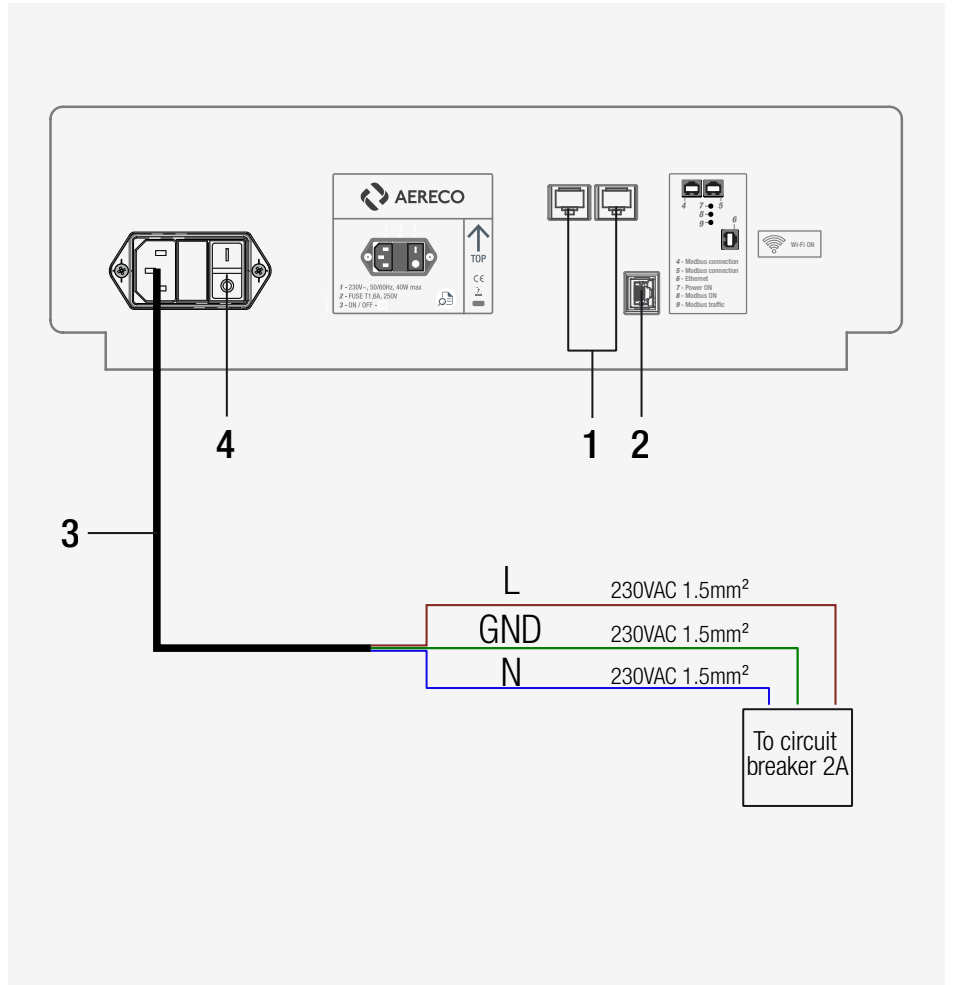

The main power supply is on the DXR Unit.

Smart Interface (optional) and 2I20 module (optional if pump or mandatory if preheater).

4.2. ELECTRICAL CONNECTION OF THE DEFROSTING

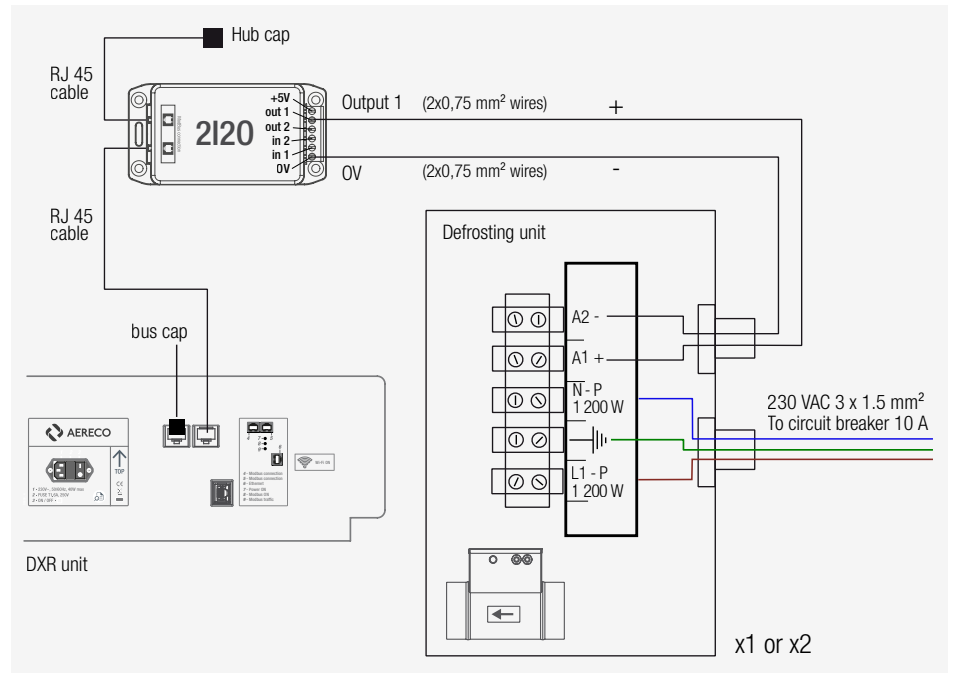

One of the 2 RJ45 Modbus socket may be used for the 2I20 connection, and a modbus cap must be plugged on the other RJ45 Modbus socket.

Details of DXR Unit and defrosting connection

The defrosting has an individual supply in 230 VAC, 50/60 Hz, single-phase via a flexible cable having a cross-sectional area of at least 1.5 mm². The control is connected via a 2 wires cable having a cross sectional area of at least 0.5 mm² and a maximal length of 30 meters.

The electrical connection must be made by a professional and comply with the standards in force in the country of installation. Plan a contact separation device having an opening distance of at least 3 mm on each pole.

Note: there is no alarm in the defrosting provided by Aereco.

4.3. ELECTRICAL CONNECTION OF THE CONDENSATE PUMP

The DXR1708 is provided with a siphon. It is still possible to connect a condensate pump after the siphon. The diagram below displays the electrical connections.

The use of an optional 2I20 module connected on a pump allows to display an alarm message in case of pump failure.

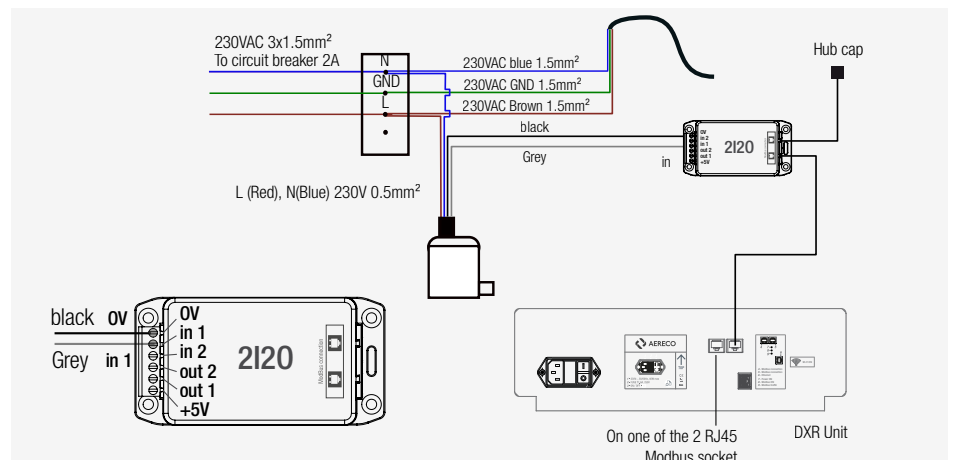

Details of condensate pump electrical connections



Dry contact alarm connections.

The alarm is connected via a 2 wires cable having a cross sectional area of at least 0.5 mm² and a maximal length of 30 meters.

5. STARTING AND SETTINGS OF THE DXR SYSTEM

5.1. WAYS TO ACCESS TO THE INTERFACE

Three kinds of connection are possible to access to the DXR's interface.

1) Communication through direct ethernet RJ45 cable

The RJ45 cable has to be plugged, on one side, in the DXR RJ45 socket (see scheme below) and, on the other side, in the laptop's or computer's RJ45 socket.

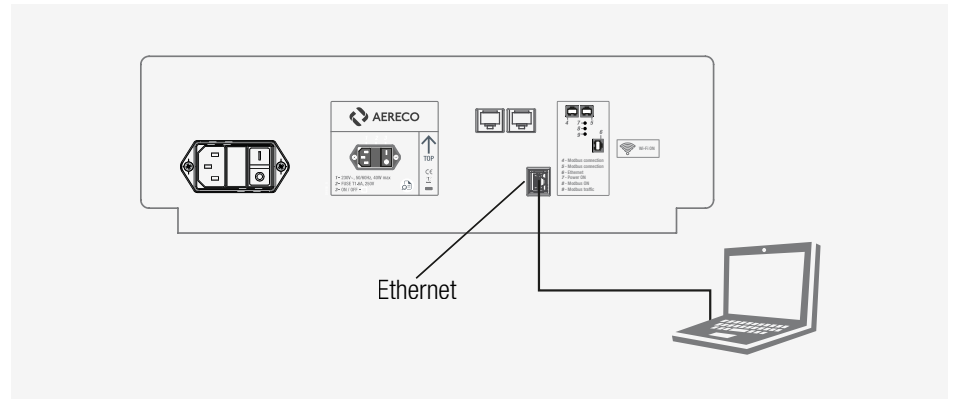

From windows explorer, in the network, click on the DXR icon: another way is to use internet browser.

On internet browser address bar (Edge, Chrome, Safari...), the following addresses give an access to the settings and to the user home page of the DXR interface:

- <http://169.254.1.20/> to go to the Home page,

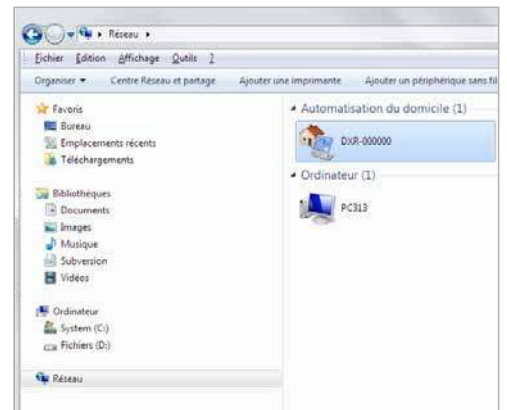
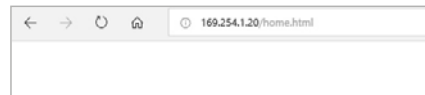

2) Communication through Wi-Fi connexion

From any smartphone or from a computer (or laptop), access to the available Wi-Fi network.

- Select the WiFi network named "DXR..."
- The password to the DXR WiFi is: **12345678**
- On the device internet browser address bar (Android, Chrome, Safari...), the following addresses give an access to the settings and to the user home page of the DXR's interface:
- <http://dxr-mb.lan/> to go to the Home page,

3) Access through a private LAN

This solution is the best one for the occupant because:

- **Solution 1** (direct ethernet access): the occupant needs to connect a PC each time he wants to access to the DXR's interface.
- **Solution 2** (direct Wi-Fi connexion): the occupant needs to connect the DX Wi-Fi (so he must disconnect the Wi-Fi, so no access to internet).
- **Solution 3** (access through the box Wi-Fi): the occupant doesn't need to proceed a manual connection. At home, the smartphone automatically connects the box Wi-Fi and, on the smartphone, pressing a shortcut button is enough to access the DX interface very easily, very user friendly.

With a connection through a private LAN

When connecting the DX unit on a LAN, a local IP address is dedicated for the DX unit. At home, the DHCP server of the inhabitant BOX automatically assigns such a local IP address. To access the DX unit through the LAN, you need to know the local IP address assigned to the DX unit. To find it, application like FING can allow you to scan the inhabitant's LAN in order to find the DX local IP address. So, it is possible to access the DX unit as soon as you are connected on the LAN (at home, your mobile automatically connects your home LAN, so the DX system access is automatic also).

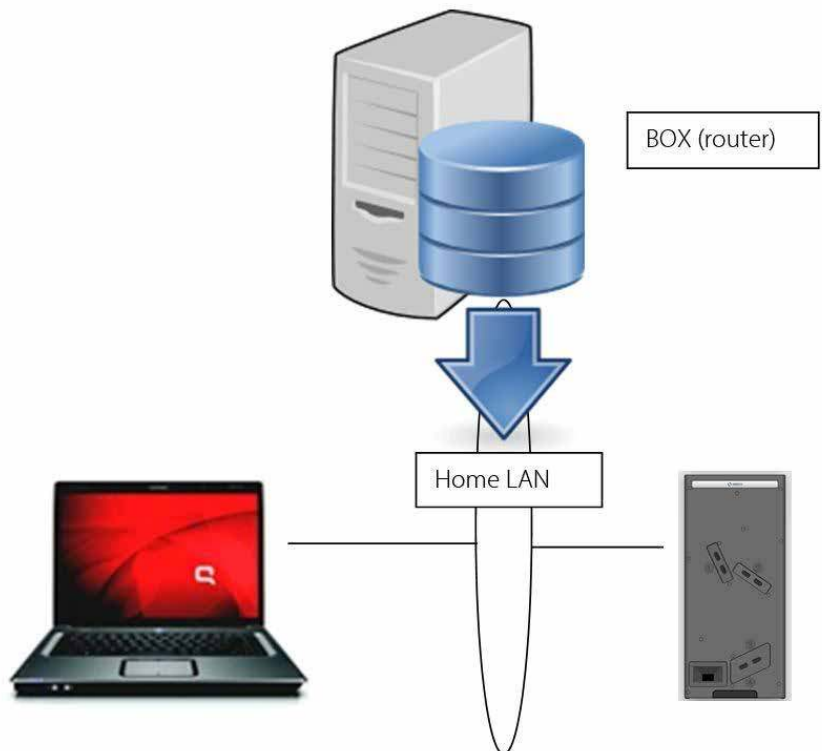

Example on a Bouygues Telecom BBox

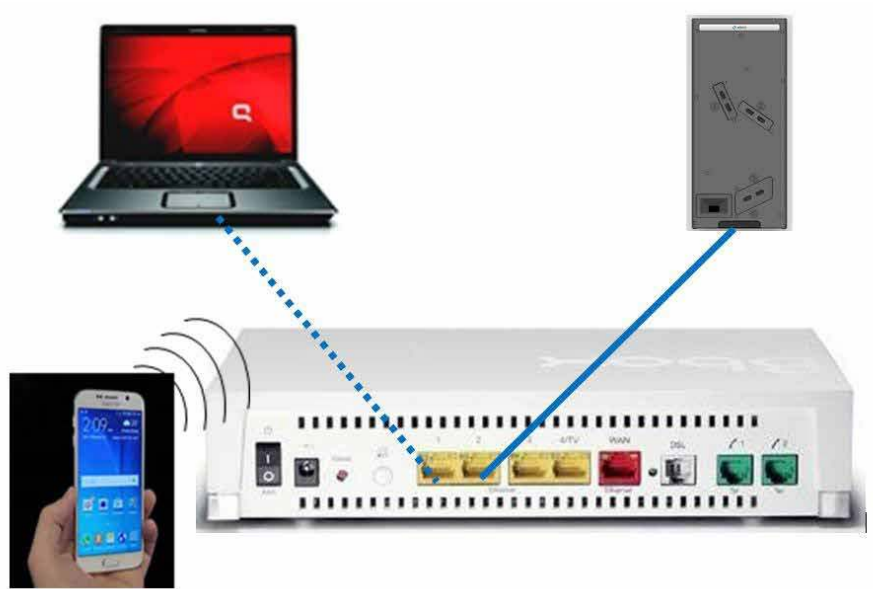

At home, the smartphone automatically connects the Box Wifi.

If the DX unit is also connected on the Box, it's possible to create a shortcut to access the DX unit. This connection is really an easy way to very friendly access the DX unit.

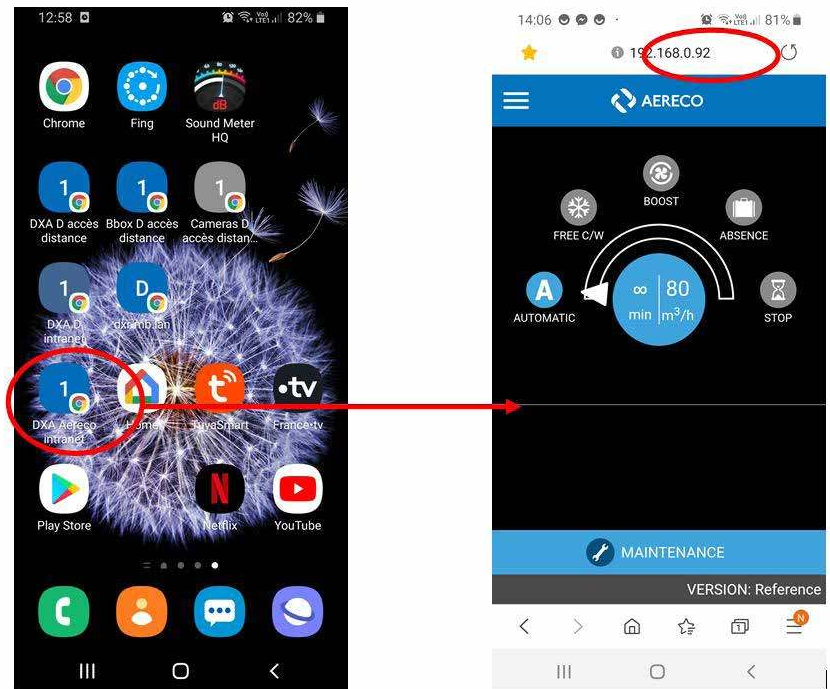

Nota 1:

To find the IP address assigned to the DX unit, a scan with FING may be performed at the first connection only.

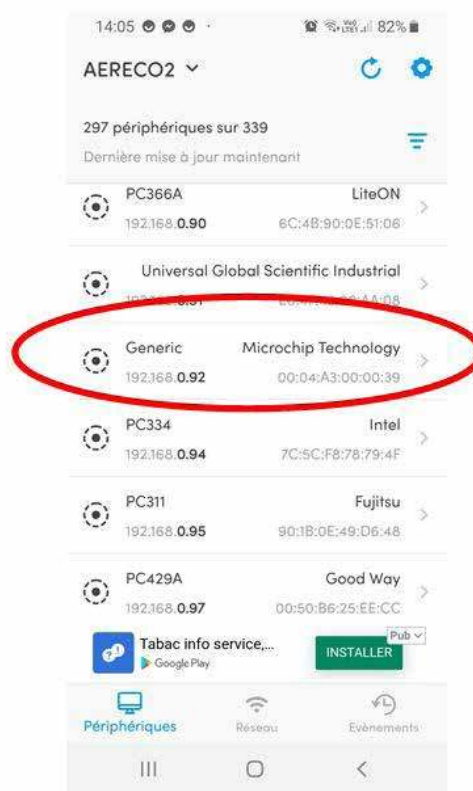

Nota 2:

To connect the DX unit on the BOX, it's also possible to place the DX unit in Station mode and to link the DX unit with the box (in the WiFi menu, enter the name of the Box Wifi network and enter the Box password). But this Wifi way is less robust than a cable linking.





5.2. DXR HOME PAGE

1) HOME

The Home page gives a clear overview of the system :

- current mode of operation
- direct way to access

2) MAINTENANCE

To get in this section, the following mentions must be used

USER : 0aereco
PASSWORD : 0aereco123

- Wifi connection

- to select the the Wifi / mode :

- AP mode (Access Point mode). The DXR unit provides its own Wifi network to be accessed with a smart phone, a laptop, or a touch pad.
- ST mode (Station mode). The DXR unit is connected on the home internet box to access internet

This menu allows :

- To enable or disable the DXR Wi-Fi,
- To change the name of the DXR Wi-Fi (named DXR when the DXR unit is delivered),
- To change the Wi-Fi password (12345678 when the DXR unit is delivered).

- System parameters

This menu allows to access 4 advanced tools.

- Synoptic. This advanced tool allows to have an overview of the whole system, with all parameters displayed. It's also possible, with the set BUS values menu, to take under control all driven parts (bypass, fan motors, defrosting unit, compensation valve, hub).
- Synoptic data charts. This tool allows to display the evolution of the device parameters.
- Configuration wizard. The wizard allows to proceed to the DXR settings. Before starting to run the DXR, make sure that all the ductwork have been correctly done. The Modbus communication cable supplies the 2I2O module (if pump or preheater) and the smart interface (if smart interface), all sensors, the compensation valve and the hub.
- Reset. This erase all configuration data kept in memory. A new configuration setting by the use of the wizard is required after a reset.

- Maintenance

- Filter clogging level
- Filter status. Reset filters each time filters are replaced
- Bypass
- Preheater

- Manufacturer access.

- K factor is use to adjust airflows. (K=100 for DXR)
- Preheater set point is the target to drive the preheater. This target is the average value of the 2 cold T° (1/2 x (outside airflow T° before heat Exchanger + Inside airflow T° after heat exchanger). This target is 1°C for the DXR when delivered by the factory.
- Preheater 1200W if 1 preheater (-20°C) / 2400W if 2 preheater (-38°C)
- Exterior T° set point fixes the minimal exterior T° to proceed free cooling (risk of condensates in the ductwork if T° is too low) and if supply ductwork is not insulated (15°C=Factory setting)
- Interior T° set point to manage the bypass (20°C=Factory setting) in order to start (automatically) a free cooling or a free warming ventilation when possible.
- G4 Min Pressure is the pressure drop on the G4 filter @230 m³/h when the G4 Filter is the

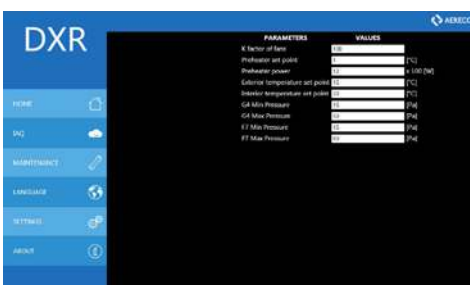
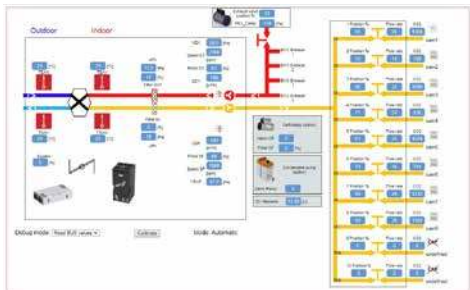
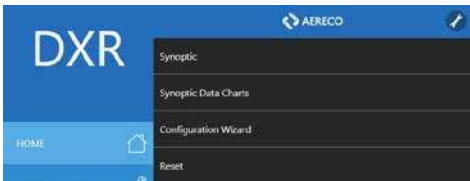

- new one (depends on the G4 filter in use).
- G4 Max Pressure is the pressure drop on the G4 filter @230 m³/h when the G4 filter must be replaced (glogged filter these value depends on the G4 Filter in use).
- F7 Min Pressure is the pressure drop on the F7 filter @230 m³/h when the F7 filter is the new one (depends on the F7 filter in use).
- F7 Max Pressure is the pressure drop on the F7 filter @230 m³/h when the F7 filter must be replaced (glogged filter these value depends on the F7 filter in use).



- **General settings to change language, bring up to date the clock, change measurement units.**

- Email account settings

The emailing feature aims the communication of a possible system warning or a fatal error to the interested people. We suggest one email address should specify the owner's one and the second email address should specify the technician in charge of the maintenance. The contact field may contain some information providing the maintenance technician with the needed customer contact.

The essential points describing the emailing feature are:

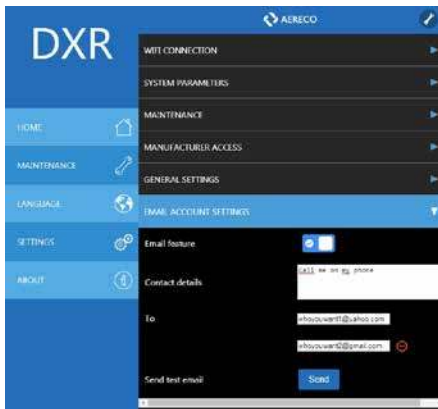

1. The emailing of the warnings feature may be enabled/disabled.
2. When enabled, the system send email to one, two or three recipients. Two recipient email addresses are configurable. The third recipient is the manufacturer, it is predefined and it is mandatory when you enable this feature.
3. There is a button to test the configuration. When you click it, the system sends email letting you to check the connectivity.
4. The information sent is:
 - a. Date and time,
 - b. Recipients email addresses
 - c. The text from the contact field
 - d. The status of the system including the event, the devices composing the system, their serial number, hardware version, software version, functioning parameters when the event happened. The status information is sent as a link onto the manufacturer cloud.
5. The manufacturer collects only the status information in anonymous fashion. The text from contact field and the email addresses are discarded.
6. To be able to email, the system needs to be connected to Internet through the local LAN (Station Mode)
7. If you are concerned about the privacy issues you may simply disable the emailing system.

3) LANGUAGE :

Shortcut to Maintenance / general settings with no need of user name and password.

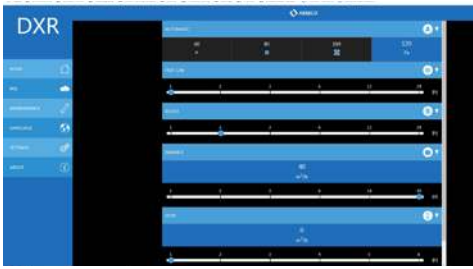

4) SETTINGS :

This menu allows to configure Automatic mode, free cooling/free warming mode, Boost mode, Absence mode and Stop mode within a choice of airflows set points and duration set points.

REGULATION RULES :

- Supply airflow = exhaust airflow
- Customer may choice within a list of different exhaust pressure measured in the compensation valve (60Pa, 80Pa, 100Pa or 120Pa).
- Dampers in the hub open according to the relevant IAQ sensor.

AUTOMATIC MODE, the DXR unit drives the exhaust fan motor in such a way that:

- Exhaust fan motor proceeds a constant pressure within the compensation valve (-60 Pa, -80 Pa, -100 Pa, or -120 Pa).
- Supply fan, motor ensure a supply airflow = exhaust airflow
- Hub damper open in such a way that according to the dedicated room air quality, room supply airflow $\geq 8 \text{ m}^3/\text{h}$ if air quality is good, and room supply airflow encreases up to $28 \text{ m}^3/\text{h}$ if room air quality is not enough.
- Compensation valve opens when the need of supply airflow is higher than current exhaust airflow.

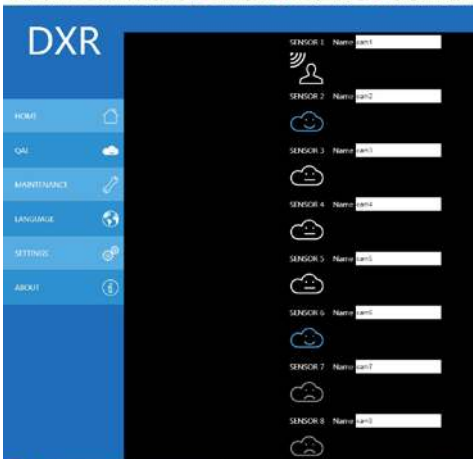

ABSENCE MODE

We've been asked to provide an absence mode as an additional mode of regulation. This mode has to be started with a human action (customer has to press on a button) and then, the customer has to choose within a durations list (1 day, 2-3-4-5-6 days, 1,2,3,4 weeks). Absence mode run a constant $40 \text{ m}^3/\text{h}$ airflow regulation.

OVER VENTILATION MODE

Over ventilation mode allows to increase ventilations airflows with the use of bypass rules. Over modulation mode has to be started with a human action (customer has to press on a button) and then, the customer will have to choose within a duration list (1-2-3-4-5-6-12-18-24 hours).

During an over ventilation period, bypass is running like if the DX system was in an automatic mode, but all dampers (in the HUB and in the compensation valve) open in such a way that supply airflows are:

- $28 \text{ m}^3/\text{h}$ in each pipe for HUB 6x75mm and HUB 8x75mm
- $40 \text{ m}^3/\text{h}$ in each pipe for HUB 6x100mm.



FREE COOLING / FREE WARMING MODE

Free Cooling mode allows to increase ventilations airflows with a Bypass ON. To enable the free cooling mode, the external T° has to be compliant with the free cooling regulation rules (need to refresh inside, and outside $T^\circ < \text{inside } T^\circ$ with outside $T^\circ > 15^\circ\text{C}$ minimum to prevent condensate phenomenon (the 15°C threshold can be set). If not, the device enables the automatic regulation waiting for the outside T° to be compliant with the free cooling mode.

To enable the free warming mode, the external T° has to be compliant with the free warming regulation rules (need to warm inside, and outside $T^\circ > \text{inside } T^\circ$). If not, the device enables the automatic regulation waiting for the outside T° to be compliant with the free warming mode.

Free Cooling / free warming mode has to be started with a human action (customer has to press on a button) and then, the customer will have to choose within a duration list (1-2-3-4-5-6-12-18-24 hours). During a free cooling / free warming period, bypass is ON, and all dampers (in the HUB and in the compensation valve) open in such a way that supply airflows are:

- $28 \text{ m}^3/\text{h}$ in each pipe for HUB 6x75mm and HUB 8x75mm
- $40 \text{ m}^3/\text{h}$ in each pipe for HUB 6x100mm.

STOP MODE, this mode allows to stop the 2 fan motors. This mode may be very useful, especially when works are proceeded in the dwelling. This mode allows not to clog the filters.

5) SYNOPTIC INTERFACE :

Through the synoptic interface, all the components status are visible and can be set up.

Synoptic is available in MAINTENANCE / SYSTEM PARAMETERS / SYNOPTIC.

Read Bus values to have an overview of the whole device.

Set Bus values to check and controle all actuators (fan motors speed, compensation valve and all hub dampers opening, by pass position, preheater order, pressure sensors calibration)

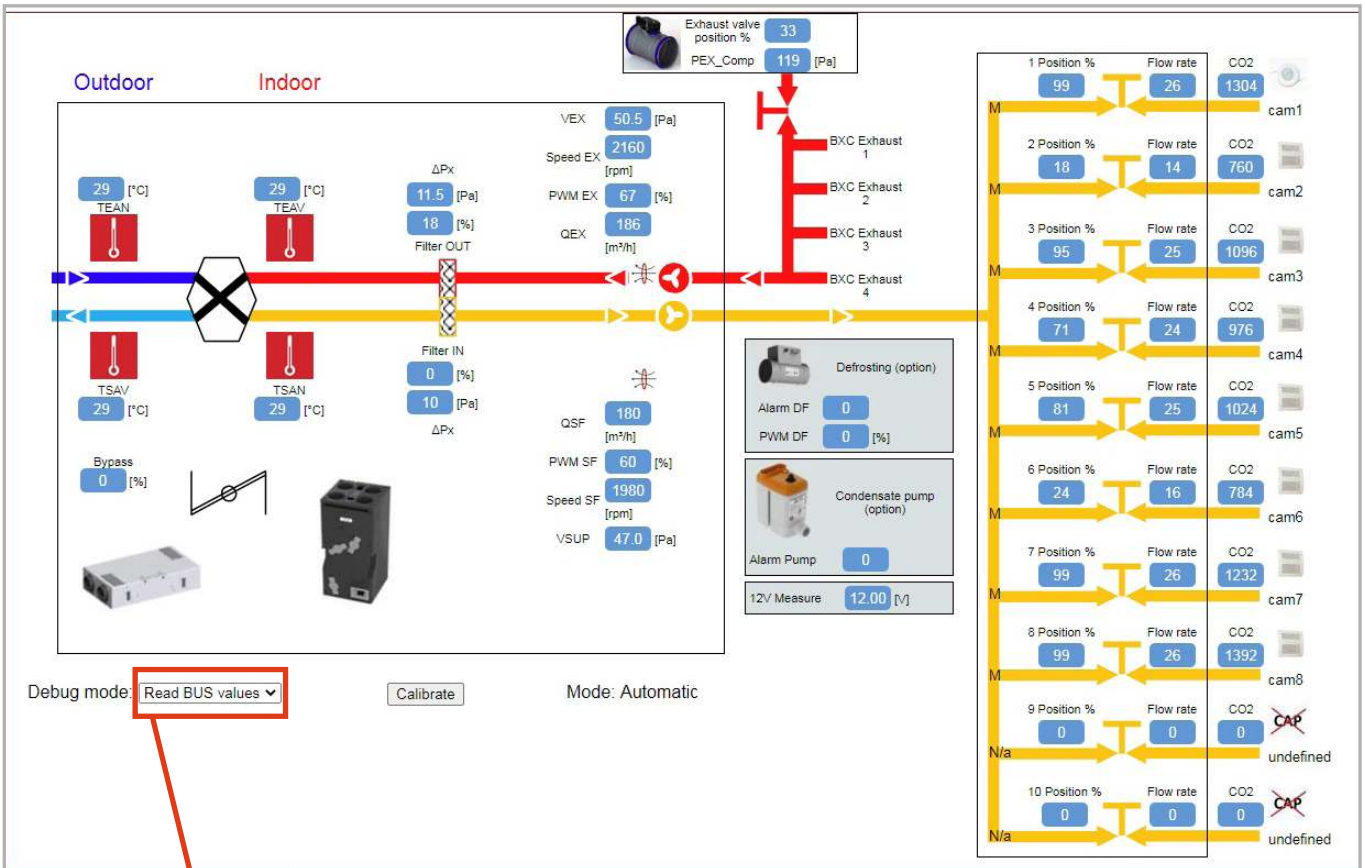

select Read BUS values
or
Set BUS values

6. FIRST START

At the first start, launch the WISARD application in:

- MAINTENANCE
- SYSTEM PARAMETERS
- Configuration Wisard.

If required (alarm message displays on the interface) and only if required, calibrate the pressure sensors in the Synoptic application (MAINTENANCE / SYSTEM PARAMETERS / synoptic).

Before calibrating, be sure there is not airflow at all in both supply and exhaust ducts networks. If no airflow, press on the calibration button.



The calibration operation must be performed by a skilled operator only.



Before starting to run the DX system, make sure that all the ductwork has been correctly done:

- The Modbus communication cable supplies the sensors and the exhaust compensation valve.
- DX ductwork is connected to the HUB, to the exhaust units and to the exhaust compensation valve.
- There is no leakage in the ductwork.

6.1. CHOICE OF LANGUAGE

Choose the corresponding image to select the language.

Remark: This choice can be changed later, in the settings menu.

6.2. CHOICE OF UNIT OF TEMPERATURE

Choose the customary unit in the country of installation (°C or °F).

Remark: This choice can be changed later, in the settings menu.

6.3. DATE OF INSTALLATION

Enter the date of installation or press "Sync and update" to synchronize with the device used for the settings.

6.4. DETERMINATION OF THE NUMBER OF SENSORS CONNECTED

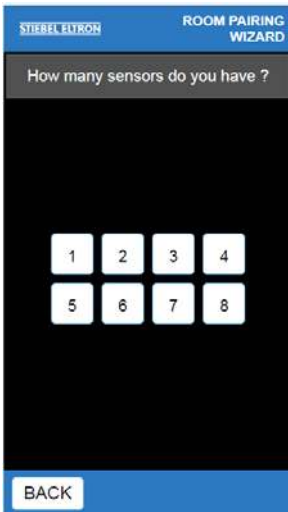

This step serves to check the connection of the CO₂ or presence sensors to the DXR unit via the RJ45 cables.

Enter the number of sensors connected to the DXR unit.

If the number of sensors entered matches to the number of sensors detected by the system, the initialization process goes to the next step. If the number of sensors entered does not match the number of sensors detected by the system, a pop-up message appears indicating the number of sensors detected by the system. Two actions are then recommended:

- a. Check that the sensors are correctly connected.
- b. Check the index of the sensors (index 1 to 8). This index number has to be different from a sensor to another one. The index numbers must be incremented to each other so that there is no digit jump. Never use the index 0

Example: if 6 sensors are in use, the index numbers must be 1, 2, 3, 4, 5, and 6

The initialization process returns to the previous step.



6.5. PAIRING OF SENSORS AND SUPPLY DUCTS

This step serves to pair the supply ducts with their CO₂ or presence sensors.

Each intermediate step consists in indicating for each room, the duct(s) supplying fresh air and the sensor(s) installed in this room. To facilitate locating the supply units, a strong stream of air emerges from the unit concerned, while the other ducts deliver the minimum airflow.

For each room, proceed as follows:

1. Enter a room name

2. Press “+” button to display the available duct(s) and a sensor for the room:

- a. Select one of the available duct to assign it to the room. Selected duct supplies higher airflow than other. Only blue duct can be chosen. Grey duct indicates duct already attributed to a room.
- b. In the corresponding room, choose the index of the sensor. If the index is correct (i.e. the index corresponds to the sensor position), the sensor's LED blinks.

3. Once, the duct(s) and the sensor(s) are paired to the room, the duct length must be determined:

- a. Short: corresponds to a length between 0.1 m to 7 m.
- b. Medium: corresponds to a length between 7 m to 12 m.
- c. Long: corresponds to a length between 12 m to 15 m.

If pipe is longer than 15m, 2 pipes may be used to ensure 28 m³/h at least.

Once the three steps are done, use the arrow to assign duct and sensor to another room.



Note: The duct / sensor pairing can be checked only if the system has been installed in accordance with good practice (limiting leaks and pressure losses in the network).

If the pairing has been correctly entered, the initialization process goes to the next step.

If the pairing of the supply units with the sensors is not correctly entered, a screen is displayed, indicating the type of error detected.

4. Finish button enables to complete and to register the device configuration.

7. HOW TO BRING UP TO DATE THE VERSIONING

With an ethernet connection, from the computer's internet browser, go to the WEB page <http://169.254/1/20/webupgrade>

USER : (only for the manufacturer staff)

PASSWORD : (only for the manufacturer staff)

Then, load the 4 files to bring up to date the whole device.

In case of major issue (fatal issue after upgrade), restart the device with the SOS version by 5 x (switch OFF - switch ON)



The upgrade operation must be performed by skilled operator only

8. MAINTENANCE



For every operation of maintenance, even replacement of filters, disconnect the electrical supply before any operation and ensure that the unit cannot be started accidentally.

Maintenance of ventilation installation helps to avoid:

- microbial contamination of the installations, with consequences on comfort and health (the impact of such contamination is aggravated in an air supply);
- loss of aeraulic performance through too high pressure drops, increase of fan consumption;
- noise (from a too high pressure, and from high speed rotation of fan due to clogged filters).

8.1. REGULAR MAINTENANCE OF THE INSTALLATION

Frequency	Maintenance
when the alarm indicates it	Replace the filters, then reset filters in the MAINTENANCE MENU.
	Fresh air inlet and exhaust air outlet: check the unobstructed passage of air (no dead leaves, no snow).
	Supply and exhaust units: cleaning as recommended by the manufacturer (this part can be done by the occupant).
once a year	Evacuation of condensates: check that the system is not obstructed by impurities. WARNING: Plan replacement of the condensates evacuation pump according to the life span announced by the supplier. If using a DXR Unit with a built-in siphon, check that siphons is filled with water. If not, it is necessary to fill the siphon with water.
	Ductwork: check and cleaning if the ductwork is obstructed.
	Exchanger: check the exchanger and clean it with a vacuum cleaner, only if necessary.
once every 5 years	Fans: <ul style="list-style-type: none"> · check the blades · check and cleaning if the grilles protecting the fans are obstructed

8.2. POWER SUPPLY AND MOTOR MATERIAL PROTECTIONS

In case of dysfunction of the appliance, these protections will be turned on. It is then necessary to disconnect the appliance during 30 seconds to restart the DXR Unit.

8.3. FILTERS

The interface indicates when the filters need to be changed. Their change is easily realised through the two access hatches (no tool needed).

The bottom cover of the DXR Unit must not be dismantled for this operation. All filters (1xG4 and 1xF7) must be replaced at the same time.

Filter removal/replacement:

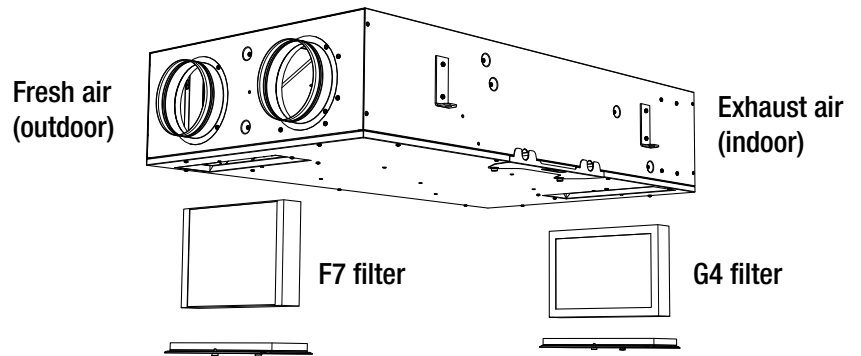

Removal

1. Switch off the unit.

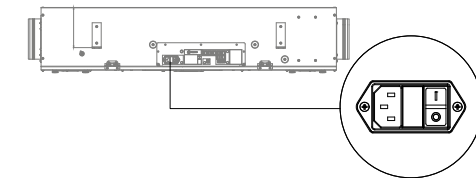

2. Remove both filter hatches
Remove 2 fixing buttons. Hold the hatches with you hand to prevent it from falling.

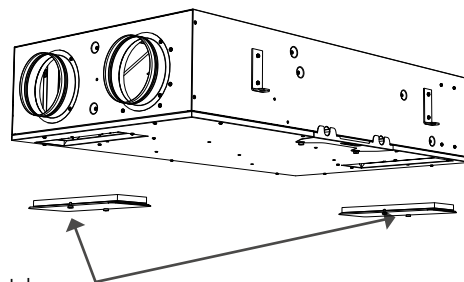

3. Remove each filter by holding it firmly along its edge and pulling it downward out of the filter slot (the filter is a push-fit item and not fastened in place).

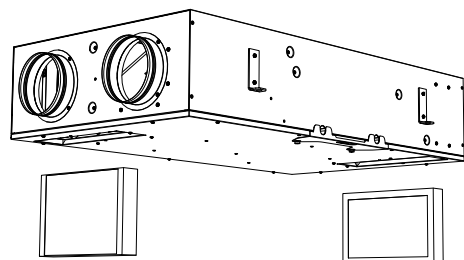

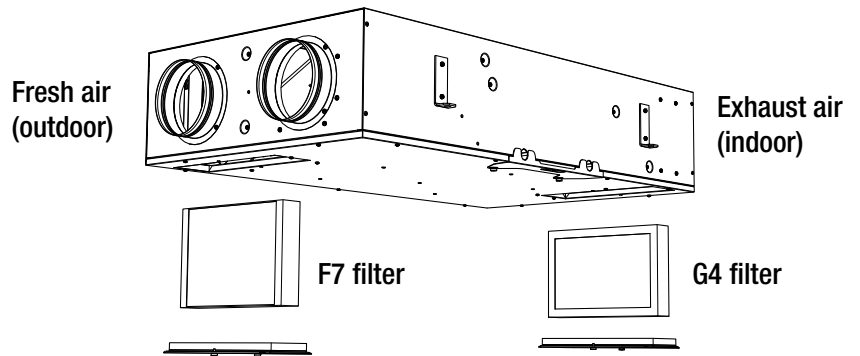

Replacement

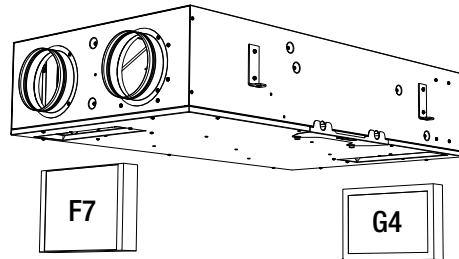

1. Ensure that the new (clean) filters are positioned in the right order.
 - G4 filters: the inscription "dust air side" on the filter must face the incoming air.
 - F7 filter: the arrow on the filter must follow the supply air path.
2. Ensure that the new (clean) filters are firmly pushed back into their slots.

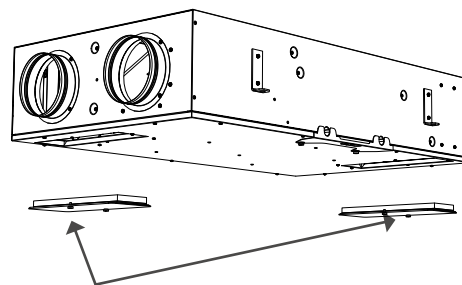

3. Replace the access hatches with 2 screws.

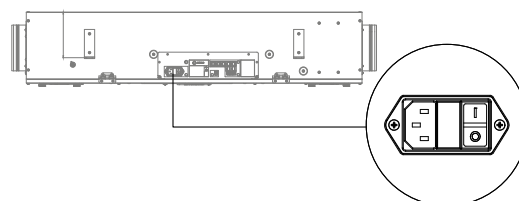

4. Switch on the unit
5. Reset the filters in the MAINTENANCE : menu MAINTENANCE / filters status / filter reset

9. TROUBLESHOOTING

Faults	Causes	Actions
Condensate leaks or water noise in the heat exchanger	Poor condensate evacuation	Make sure the external pipes have been installed properly. Siphon has to be full of water.
	Poor condensate evacuation (Using a lift pump)	Make sure it is correctly working according pump's manual.
Low airflow levels at grilles	Network leaks	Inspect the aeraulic network and sealing.
Cold incoming air supply	Bypass open	<ul style="list-style-type: none"> - Make sure the bypass is in good condition and the motor is operating properly. - Re-start the DXR Unit by disconnecting it during 30 seconds from power. - Control filter clogging, and if necessary, replace them. - Check with the synoptic tool all T°
	Defrosting default Supply ductwork insulation	<ul style="list-style-type: none"> - Make sure the airflow rate is not too low. - Check the unobstructed passage of air in the defrosting - Make sure ductwork are placed in a warm area or they are properly insulated.
The motors are not working	Power supply	Make sure the DXR Unit is connected to the main electrical board.
	Aeraulic network not connected	Connect the network
	Pressure loss or major leakage on the network	<ul style="list-style-type: none"> - Improve the network installation, use the recommended grilles and roof exhausts - Be sure to respect the recommendations of installation
The motors are running too fast	Too high number of extraction grille	Check the operating limits
	Filters are clogged	Make sure filters have been changed when system asked for it.
The system makes noise of vibrations	Heat exchanger is frozen (Using a defrosting)	<ul style="list-style-type: none"> - Make sure the defrosting is connected to the 2I2O module and to the main. - Make sure the defrosting is taken into account in the parameters of the DXR Unit user's interface. - Make sure the manual reset of the defrosting has not been triggered. In case it has been triggered, check the unobstructed passage of the air near the defrosting before resetting the security.
	The Unit is fixed in the wrong way	Make sure the system is fixed as explained in the recommendations of installation
How to reset the device ?	Configuration may be changed by launching the Wisard application (parameters remain the same)	<ul style="list-style-type: none"> - To erase all parameters, proceed a reset in MAINTENANCE / SYSTEM PARAMETERS / RESET. Then, launch the Wisard application. Parameters have to be set again (Pressure / T° set points, durations, K factors, etc.)

10. ACCEPTANCE OF WORKS

10.1. VISUAL INSPECTION

GENERAL

- Supply units in every main rooms (living room, bedroom) (accessibility)
- Door relief vent (2 cm in the kitchen, 1 cm in every other rooms)
- Exhaust units in the utility rooms (accessibility)
- Positioning of the defrosting in the fresh air duct (direction shown by the arrows)
- Access hatch for the defrosting if preheater

Remarks

DXR UNIT

- Accessibility for the DXR Unit
- Positioning of the DXR Unit (vertical) and fixation of the DXR Unit to the wall
- Conformity of connection (direction shown by the arrows on the DXR Unit)
- Connection sleeve at the DXR Unit and airtightness of the connections
- Exhaust air and fresh air duct (insulated and Ø160 mm)
- Exhaust balancing (in each utility room)
- Supply balancing (in each utility room)
- No spilages on the exhaust duct network
- No spilages on the supply duct network

Remarks

ELECTRICAL DEVICE

- Supply voltage
- Ground connections
- Individual electrical connection for electrical device (defrosting, DXR Unit)

Remarks

START

- Working of the interface

Remarks

10.2. COMMISSIONING PROCEDURE FOR AERECO DXA MODBUS EXCELLENCE

Before measuring the airflow be sure that the installation is well done. For that ensure that all the points below are checked.

VISUAL INSTALLATION CHEKING		Remarks
Supply units are put in every main rooms (living room, bedroom) (accessibility)	<input type="checkbox"/>	
Door relief vent (2 cm in the kitchen, 1 cm in every other rooms)	<input type="checkbox"/>	
Exhaust units put in the utility rooms (toilet, bathroom, kitchen...) (accessibility)	<input type="checkbox"/>	
Positioning of the defrosting in the fresh air duct (direction shown by the arrows)	<input type="checkbox"/>	
Access hatch for the defrosting	<input type="checkbox"/>	
Positioning and level of the DXA Unit (vertical) and fixation of the DXA Unit to the wall	<input type="checkbox"/>	
Conformity of duct connection (direction shown by the arrows on the DXA Unit)	<input type="checkbox"/>	
Flexible connection sleeve at the DXA Unit and airtightness of the connections	<input type="checkbox"/>	
Exhaust air and fresh air duct (insulated and Ø160 mm)	<input type="checkbox"/>	
Supply voltage 230V	<input type="checkbox"/>	
Ground connections	<input type="checkbox"/>	
RJ 12 and RJ 45 connections	<input type="checkbox"/>	
Individual electrical connection for electrical device (defrosting, DXA Unit)	<input type="checkbox"/>	
Check that the ducts are single or double according to the design sheet	<input type="checkbox"/>	
Check that siphon or pump evacuation works properly (pipes are not stuck, and sealing is tight)	<input type="checkbox"/>	
Duct connections are tight	<input type="checkbox"/>	
RJ cable connections are <10m (cables cut to the min necessary length)	<input type="checkbox"/>	
Extract compensation valve is installed in the right direction (arrow shows airflow direction)	<input type="checkbox"/>	
Extract compensation valve is installed approx. at the same distance from DX unit as the furthest extract grill	<input type="checkbox"/>	
The position of the presence and/or CO2 sensors is according to the installation guide	<input type="checkbox"/>	
Extract compensation valve is accessible by hatch	<input type="checkbox"/>	

10.3. TESTS AND MEASUREMENTS:

DEVICE CHECKING

If pump, test the pump to be sure condensates water is properly rejected.

Actions

Disconnect the pipe on the pump (DXR) or take the pump test pipe (DXA), pour some water and be sure the water evacuation in the waste water network is OK.

Set the machine to mode AUTO by selecting it on the web interface



Check the pressure in all BXC is OK

Select the pressure of the system according to the dimensioning sheet (60Pa, 80Pa, 100Pa or 120Pa). Wait some minutes until the system finds the balance and measure the pressure on the BXC grills one by one.

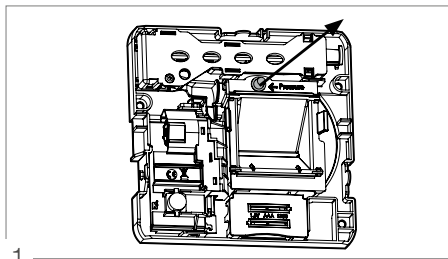

1

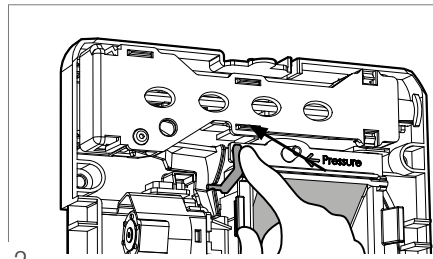

2

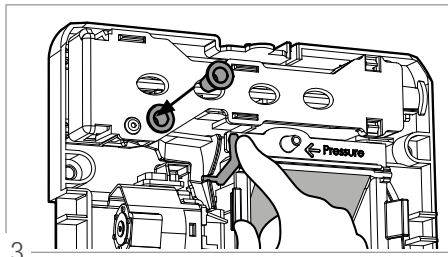

3

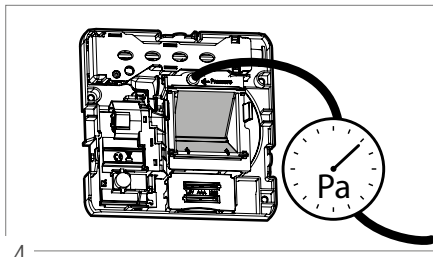

4

Don't forget to put the cap back on the pressure measurement hole

BXC1 pressure =
 BXC2 pressure =
 BXC3 pressure =
 BXC4 pressure =

To be OK, the measured pressure must be the pressure set point +/- 20Pa.

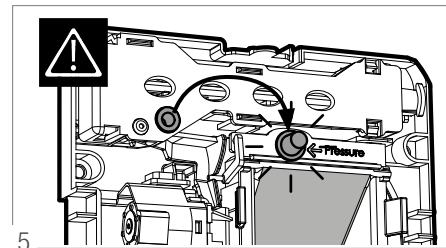

5

In the Factory parameters, check the values (some values may be changed according to inhabitant expectations):

- K factor: 113 for a DXA, 100 for a DXR (mandatory values),
- Filter clogging threshold: 100% before launching a warning message (may be changed),
- Preheater set point, average cold T°: +2°C for DXA and +1°C for DXR;
- Exterior temp set point: 15°C (to prevent condensates in the supply network during free cooling, may be changed (decreased) if pipe insulation is OK),
- Interior temp set point: 20°C (according to the inhabitant expectation and the warming device set point).

Go to manufacturer access and take a screen shot to put it in the commissioning sheet

Check the device parameters and take a Factory parameters display copy:

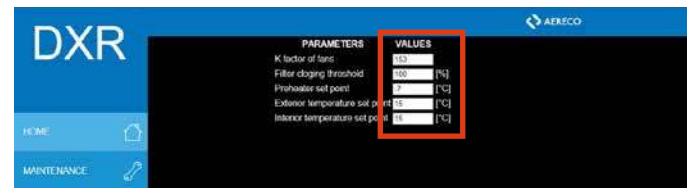
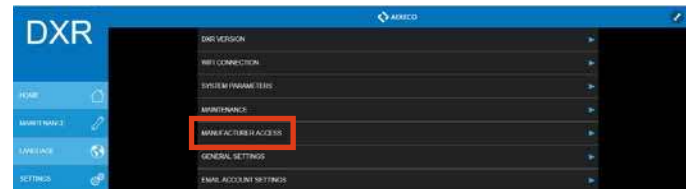
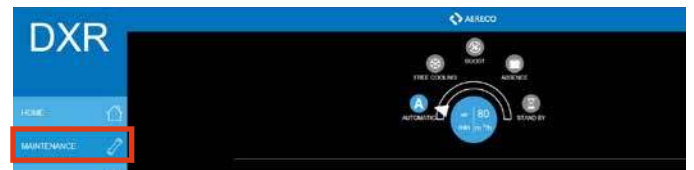

How to load the synoptic page :

Connect to the web interface with a smartphone or PC, and go to the MAINTENANCE menu,

In automatic mode, after 2/3 mn (regulation stabilisation), take a synoptic display copy.

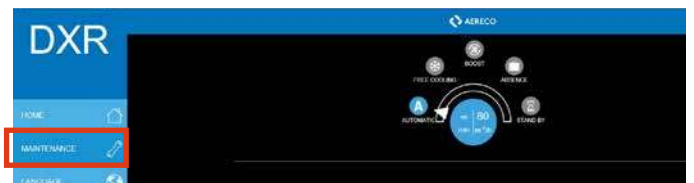

Username: Oaereco
Password: Oaereco123

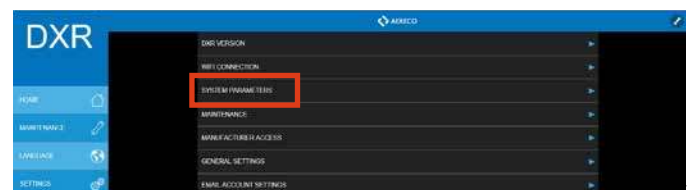

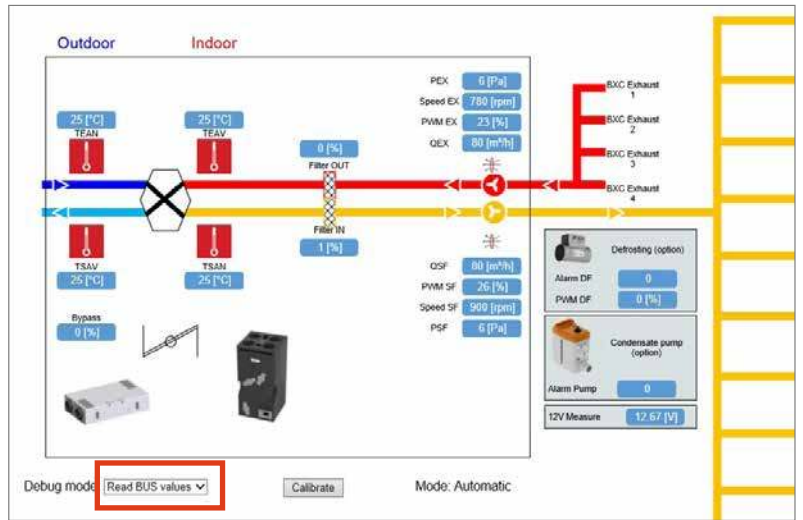
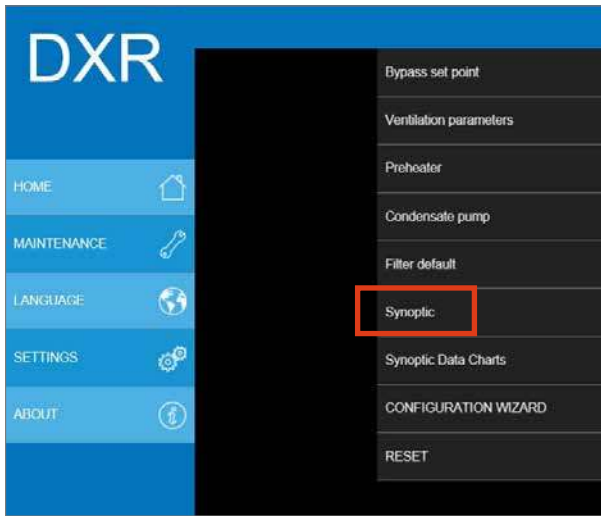

ON THIS SYNOPTIC DISPLAY, IN "READ BUS VALUES":

Check if supply Qsf and extract Qex are balanced

Check T° are all compliant with the heat exchanger efficiency

Check T° are compliant with the inside and outside T° (ductwork insulation)

Check the 2 fan motors speed are compliant with relevant airflows (see on curves)

Check pressure in the compensation valve is compliant with the pressure set point (-60Pa, -80Pa, -100Pa or -120Pa)

Check that Pex is the right value you've chosen for automatic mode.

Remarks

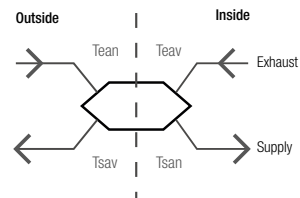

$\mu_{supply} = ((T_{san}-T_{eav}) / (T_{eav}-T_{eav}))$ (must be 0,93 +/-20% for DXA and 0,84 +/-20% for DXR)

$\mu_{exhaust} = ((T_{eav}-T_{sav}) / (T_{eav}-T_{eav}))$ (must be 0,93 +/-20% for DXA and 0,84 +/-20% for DXR)

Teav must be equal to inside T° +/- 2°C
Teav must be equal to outside T° +/- 2°C

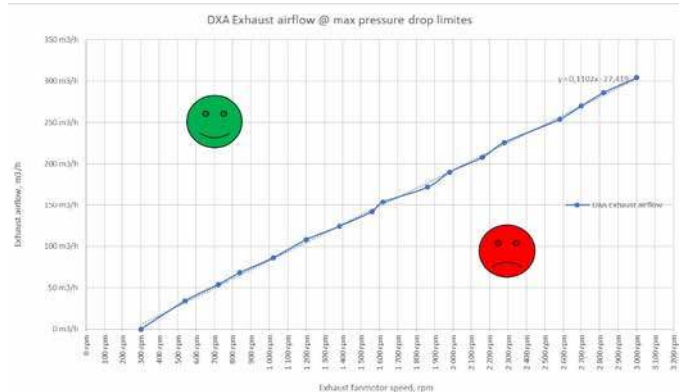

If measurement is in the bad area, check the pressure drops on the network (especially grilles, air inlets, length / shape of the pipes and no bottleneck in the pipes).

Take a screenshot of the synoptic page and attach it to the commissioning excel sheet.



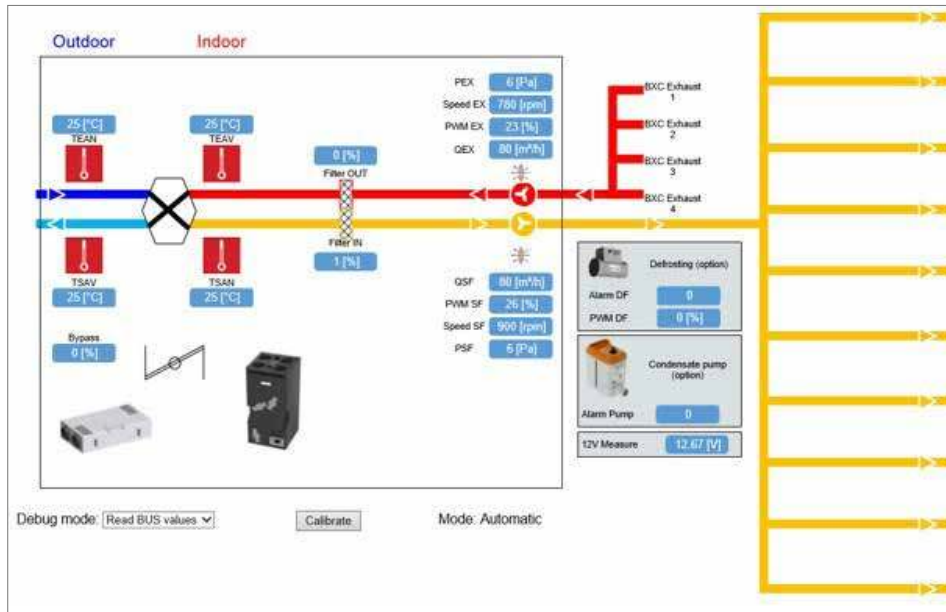

FROM THE SYNOPTIC, IN "SET BUS VALUES":

Remarks



- Test the compensation valve opening,

Test airflow when the compensation is opened and no airflow when the compensation valve is closed.
Measure compensation valve airflow under 60Pa, must be more than 150m³/h

Wait some minutes until the incoming air temperature (TEAN) begins to increase.

- Test the HUB dampers opening, pipe by pipe.

Test airflow when the pipe damper is opened and no airflow when the compensation valve is closed.



1. Test the preheater functioning (if preheater).

If preheater, start à 100% preheater warming and check the Tean T° increases (to be allowed to warm, supply airflow must be more than 50m³/h)
Set then the PWM of the preheater to 100%

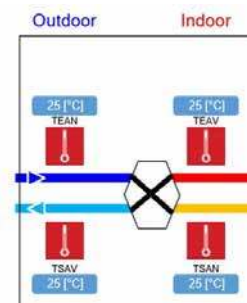

Test the by-pass functioning (reading the T° on the synoptic).
When Bypass is opened, Tean = Tsan,
When bypass is closed, Tean \neq Tsan if Tean \neq Teav

EXHAUST CHECKING:

In automatic mode, remove all BXC hygro modules in order to set them at the max airflow point (max opening).

- Measure each BXC airflow (must be registered in the commissioning document) and check measured airflow is compliant with theoretical airflow.

- BXC1 max airflow
- BXC2 max airflow
- BXC3 max airflow
- BXC4 max airflow

- Check the sum the amount exhaust airflow (full opened BXCs + Compensation valve) is compliant with the exhaust airflow displays on the synoptic (+/- 20%).

This test allows to assess the air leakages in the Exhaust network. If too many spillages, check the exhaust ductwork.

Then, place again the hygro modules in each BXC and clip the front cover.

Remarks

Unclip the hygro module to make the mobile damper fully open (BXC at its max airflow)

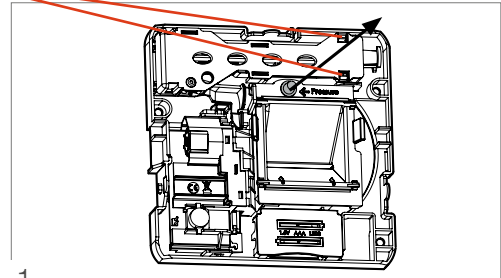

1

SUPPLY CHECKING

In boost mode, after 5mn (regulation stabilisation) check on the synoptic the compensation valve is not fully closed. If the compensation valve is fully opened, remove on 1 BXC the hygro module in order to set it at the max airflow point (max opening). So, the compensation valve shouldn't be fully opened anymore.

- Measure each pipe airflow and check measured airflow is compliant with theoretical airflow.

- Pipe 1 max airflow =
- Pipe 2 max airflow =
- Pipe 3 max airflow =
- Pipe 4 max airflow =
- Pipe 5 max airflow =
- Pipe 6 max airflow =
- Pipe 7 max airflow =
- Pipe 8 max airflow =

- If measurements are not compliant with max airflows (28m³/h +/- 20%), change in the WIZARD the pipe length (Short / Medium / Long) and if too many airflow, use a piece of foam glued into the pipe to reduce max airflow. And measure again all the 8 pipes.

- Check the sum the amount supply airflow (measured at the end of each supply pipe) is compliant with the supply airflow displays on the synoptic (+/- 20%).

This test allows to assess the air leakages in the Supply network. If too many spillages, check the exhaust ductwork.

Remarks

Link to standard dimensioning sheet:

https://aereco100-my.sharepoint.com/personal/ramdane_latri_aereco_com/Documents/Technical%20Support%20Group/DX/DX%20System%20Calculation%20BETA%20Update.xlsx

10.4. COMMISSIONING REGISTRATION FOR AERECO DX MODBUS EXCELLENCE

VISUAL INSTALLATION CHEKING	OK	NOK
Supply units are put in every main rooms (living room, bedroom)(accessibility)	<input type="checkbox"/>	<input type="checkbox"/>
Door relief vent (2 cm in the kitchen, 1 cm in every other rooms)	<input type="checkbox"/>	<input type="checkbox"/>
Exhaust units put in the utility rooms (toilet, bathroom, kitchen...) (accessibility)	<input type="checkbox"/>	<input type="checkbox"/>
Positioning of the defrosting in the fresh air duct (direction shown by the arrows)	<input type="checkbox"/>	<input type="checkbox"/>
Access hatch for the defrosting	<input type="checkbox"/>	<input type="checkbox"/>
Positioning and level of the DXA Unit (vertical) and fixation of the DXA Unit to the wall	<input type="checkbox"/>	<input type="checkbox"/>
Conformity of duct connection (direction shown by the arrows on the DXA Unit)	<input type="checkbox"/>	<input type="checkbox"/>
Flexible connection sleeve at the DXA Unit and airtightness of the connections	<input type="checkbox"/>	<input type="checkbox"/>
Exhaust air and fresh air duct (insulated and Ø160 mm)	<input type="checkbox"/>	<input type="checkbox"/>
Supply voltage 230V	<input type="checkbox"/>	<input type="checkbox"/>
Ground connections	<input type="checkbox"/>	<input type="checkbox"/>
RJ 12 and RJ 45 connections	<input type="checkbox"/>	<input type="checkbox"/>
Individual electrical connection for electrical device (defrosting, DXA Unit)	<input type="checkbox"/>	<input type="checkbox"/>
Check that the ducts are single or double according to the design sheet	<input type="checkbox"/>	<input type="checkbox"/>
Check that siphon or pump evacuation works properly (pipes are not stuck, and sealing is tight)	<input type="checkbox"/>	<input type="checkbox"/>
Duct connections are tight	<input type="checkbox"/>	<input type="checkbox"/>
RJ cable connections are <10m (cables cut to the min necessary length)	<input type="checkbox"/>	<input type="checkbox"/>
Extract compensation valve is installed in the right direction (arrow shows airflow direction)	<input type="checkbox"/>	<input type="checkbox"/>
Extract compensation valve is installed approx. at the same distance from DX unit as the furthest extract grill	<input type="checkbox"/>	<input type="checkbox"/>
The position of the presence and/or CO2 sensors is according to the installation guide	<input type="checkbox"/>	<input type="checkbox"/>
Extract compensation valve is accessible by hatch	<input type="checkbox"/>	<input type="checkbox"/>

TESTS AND MEASUREMENTS:

OK

NOK

Device checking:

If pump, test the pump to be sure condensates water is properly rejected.

Check the pressure in all BXC is OK

BXC1 pressure =

BXC2 pressure =

BXC3 pressure =

BXC4 pressure =

Check the device parameters and take a Factory parameters display copy:

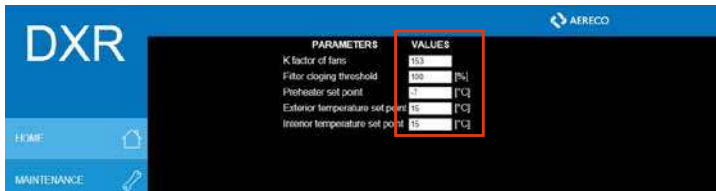

In automatic mode, after 2/3 mn (regulation stabilisation), take a synoptic display copy.

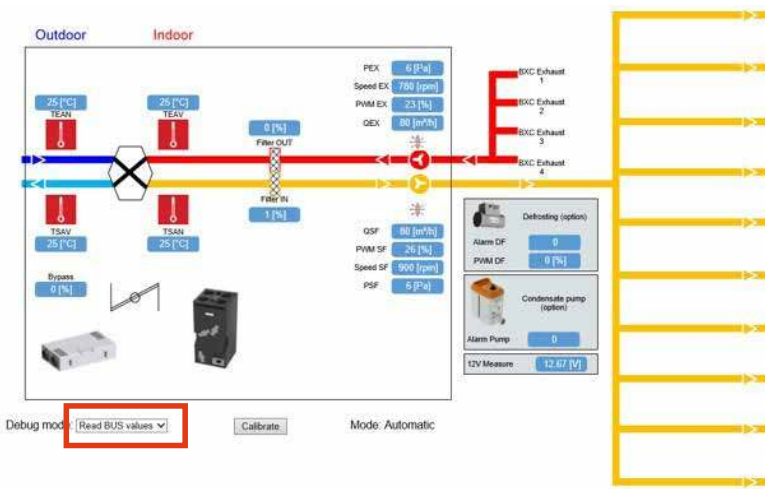

On this synoptic display, in "read BUS values":

- Check if supply Qsf and extract Qex are balanced
- Check T° are all compliant with the heat exchanger efficiency

$$\mu_{supply} = ((T_{san}-T_{ean}))/((T_{eav}-T_{ean}) =$$

$$\mu_{exhaust} = ((T_{eav}-T_{sav}))/((T_{eav}-T_{ean}) =$$

Check T° are compliant with the inside and outside T° (ductwork insulation)

Check the 2 fan motors speed are compliant with relevant airflows (see on curves)

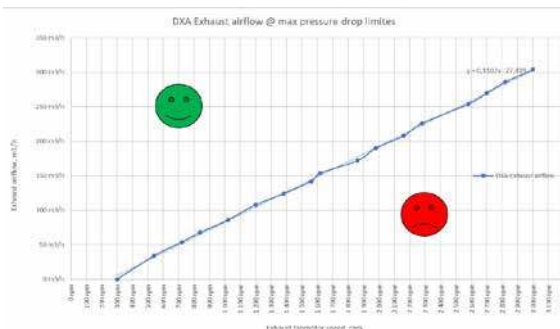

TESTS AND MEASUREMENTS:	OK	NOK
<p>From the synoptic, in "Set BUS values":</p> <ul style="list-style-type: none"> • Test the compensation valve opening, • Test the HUB dampers opening, pipe by pipe. • Test the by-pass functioning (reading the T° on the synoptic) 	<input type="checkbox"/>	<input type="checkbox"/>
<p>Exhaust checking:</p> <p>Measure each BXC airflow (must be registered in the commissioning document) and check measured airflow is compliant with theoretical airflow.</p> <p>BXC1 max airflow BXC2 max airflow BXC 3 max airflow BXC4 max airflow</p> <p>Check the sum the amount exhaust airflow (full opened BXC's + Compensation valve) is compliant with the exhaust airflow displays on the synoptic (+/- 20%).</p>	<input type="checkbox"/>	<input type="checkbox"/>
<p>Supply checking:</p> <p>Measure each pipe airflow and check measured airflow is compliant with theoretical airflow.</p> <p>Pipe 1 max airflow Pipe 2 max airflow Pipe 3 max airflow Pipe 4 max airflow Pipe 5 max airflow Pipe 6 max airflow Pipe 7 max airflow Pipe 8 max airflow</p> <p>Check the sum the amount supply airflow (measured at the end of each supply pipe) is compliant with the supply airflow displays on the synoptic (+/- 20%).</p>	<input type="checkbox"/>	<input type="checkbox"/>

11. SPECIFIC RECOMMENDATIONS FOR AIRTIGHTNESS AND INSULATION OF THE INSTALLATION

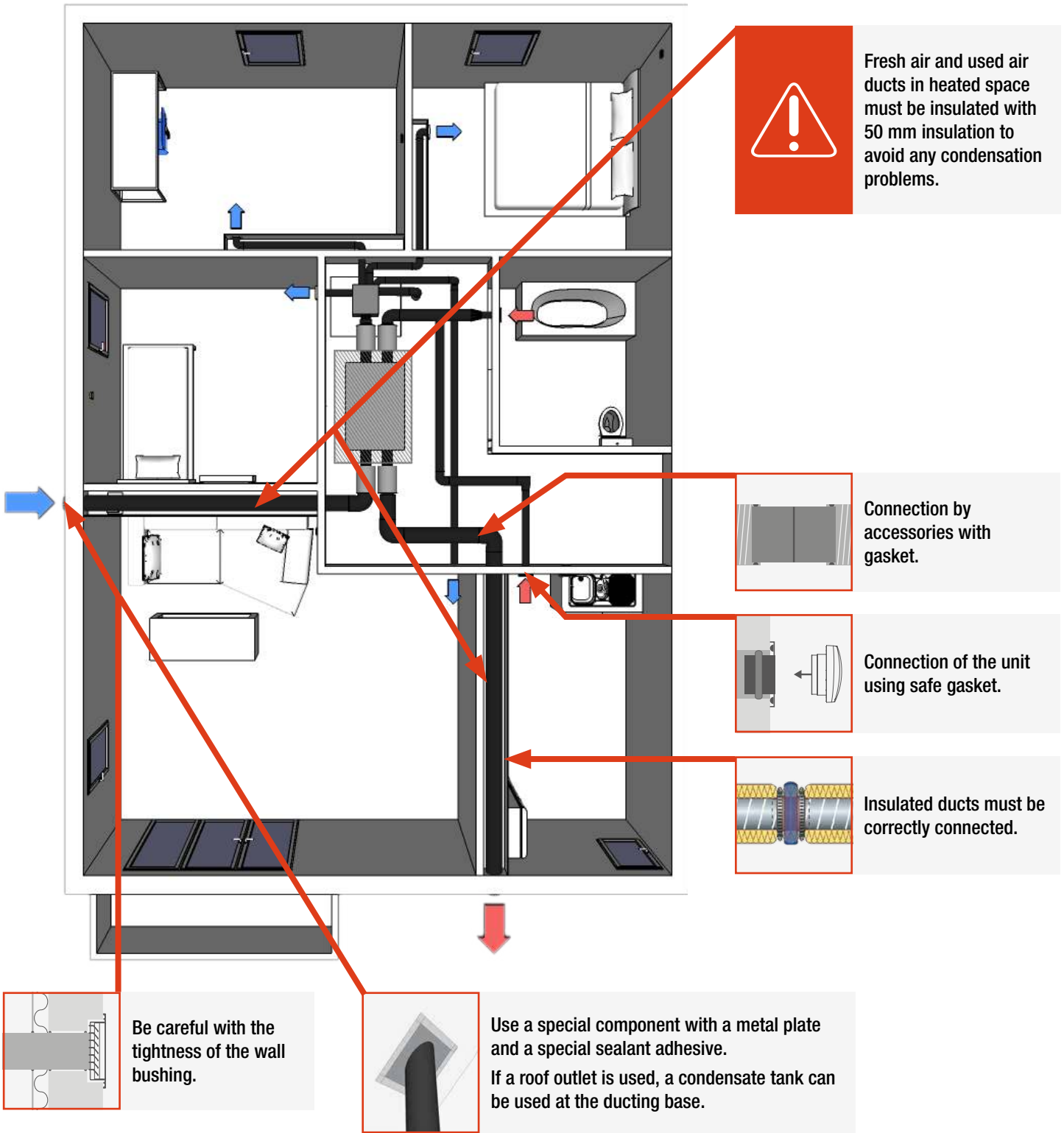

!
 Fresh air and used air ducts in heated space must be insulated with 50 mm insulation to avoid any condensation problems.

!
 Connection by accessories with gasket.

!
 Connection of the unit using safe gasket.

!
 Insulated ducts must be correctly connected.

!
 Be careful with the tightness of the wall bushing.

!
 Use a special component with a metal plate and a special sealant adhesive.
 If a roof outlet is used, a condensate tank can be used at the ducting base.

!
 To remain airtight in the long term, the ductwork must be mechanically strong (attachment between duct elements) and correctly supported. Failing this, the sag may eventually crack the mastic.
 Any duct carrying hot air that is outdoors or in an unheated volume must be insulated with 50 mm of glass wool or equivalent.

11.1. INSULATION OF THE INSTALLATION

In cases where the ductwork must be insulated, the use of prefabricated double wall ducts and accessories should be favoured to obtain good thermal performance.

External insulation on site is possible, **but care must be taken not to create thermal bridges, and the insulation must be attached securely enough to prevent its moving.** This is quite tricky on shaped parts, singularities, branch, ducts, etc.

- Step **1**: ensure airtightness of the internal face of the duct by glue or tape.
- Step **2**: tighten with a clamp, so that the connection is mechanically strong in the long term.
- Step **3**: pull the insulation to avoid thermal bridges.
- Step **4**: tighten the insulation with a clamp, to avoid its removal.
- Step **5**: if two ducts are to be connected, use an adhesive tape to airtight the two pieces of insulation.

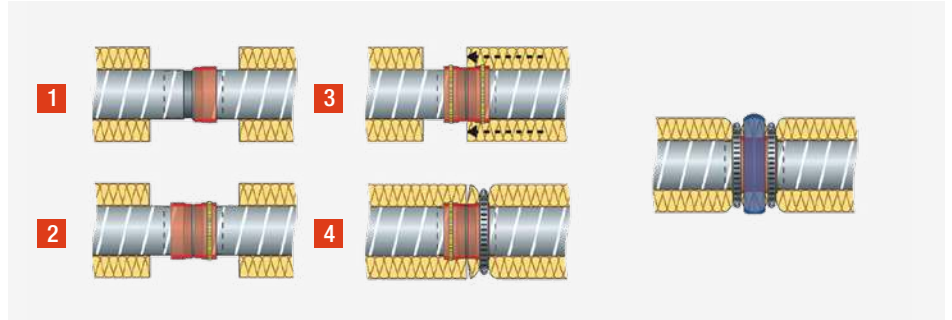

Connection of insulated ducts © CSTB

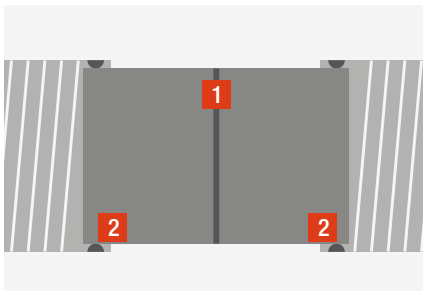

Connection by accessory with gasket

- 1** Connection with gaskets
- 2** Gaskets

11.2. AIRTIGHTNESS OF THE INSTALLATION

To make ductwork sufficiently airtight, the use of prefabricated accessories with gaskets is an ideal solution (bends, junctions between ducts).

The use of such hardware also facilitates the installation of the ductwork: thanks to the gasket, all that remains is to ensure the mechanical strength of the ductwork. There is no need for adhesive tape or mastic. Rivets or self-piercing screws can be used to make accessories and ductwork with gaskets as explained by the manufacturers.

If it is not planned to use accessories with gaskets, it is essential to use a special airtight ventilation adhesive at each junction between ducts, or mastic. Take care also to do as little cutting as possible on site.

Any bushings (through walls, the roof, etc.) must be made with rigid duct.



In order to ensure proper airtightness where ducts pass through walls, we strongly recommend leaving adequate space for the ducts.

The connection between the ventilation units and the duct is one of the most sensitive points with respect to airtightness. In all cases, the junction between the unit and the duct must be airtight.

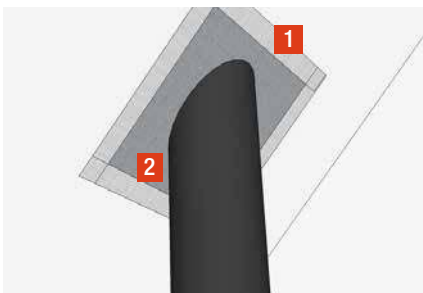

Sealing part for the bushing in a wall giving on the exterior

- 1** Special tighten adhesive
- 2** Metal sheet

We recommend connecting the units to the terminal ducts by means of a coupling, preferably with gaskets, in order to ensure a proper junction between the exhaust unit and the duct. The coupling must be bedded to ensure airtightness between the dwelling and the supporting wall. Failing this, any other system that provides equivalent tightness while nevertheless leaving it possible to remove the device can be considered.

A special component with a metal plate at the wall in contact with the exterior and a special sealant adhesive can be used to ensure the airtightness of the wall bushing.

Recommendations to control the tightness of the roof bushing:

- 1** Roof hoods
- 2** Mastic seal
- 3** Skylight frame
- 4** Bonding with vapour barrier adhesive tape or pose of a sleeve with adhesive tape
- 5** Vapour barrier
- 6** Mastic seal

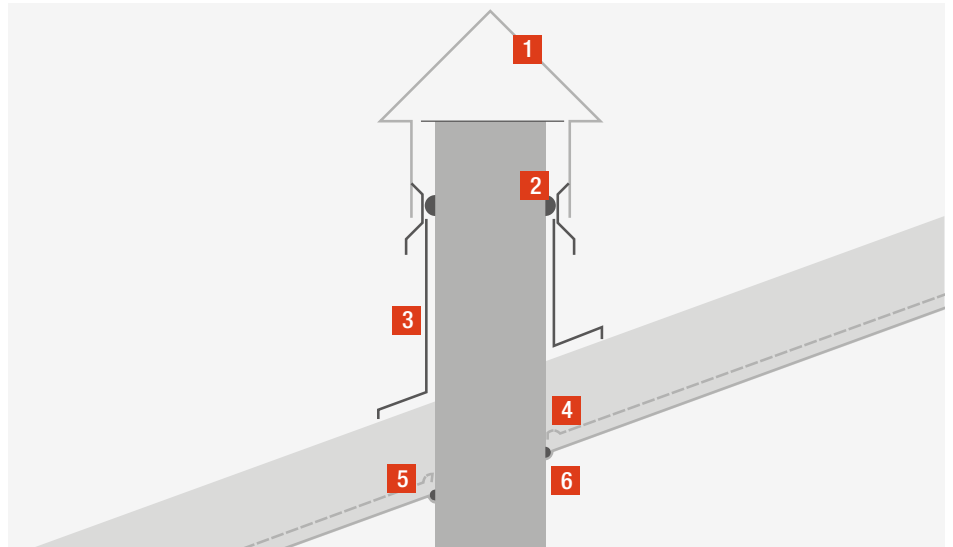

Airtightness of roof outlet

Recommendations to control the tightness of the wall bushing:

- 1** Insulation
- 2** Mastic seal
- 3** Tube

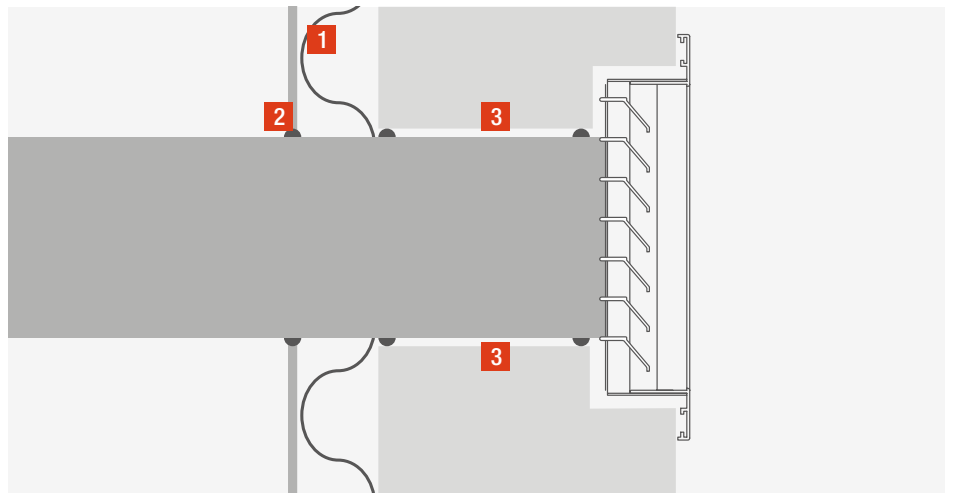

Airtightness of wall-mounted outlet

12. SUPPLY AND EXHAUST UNITS

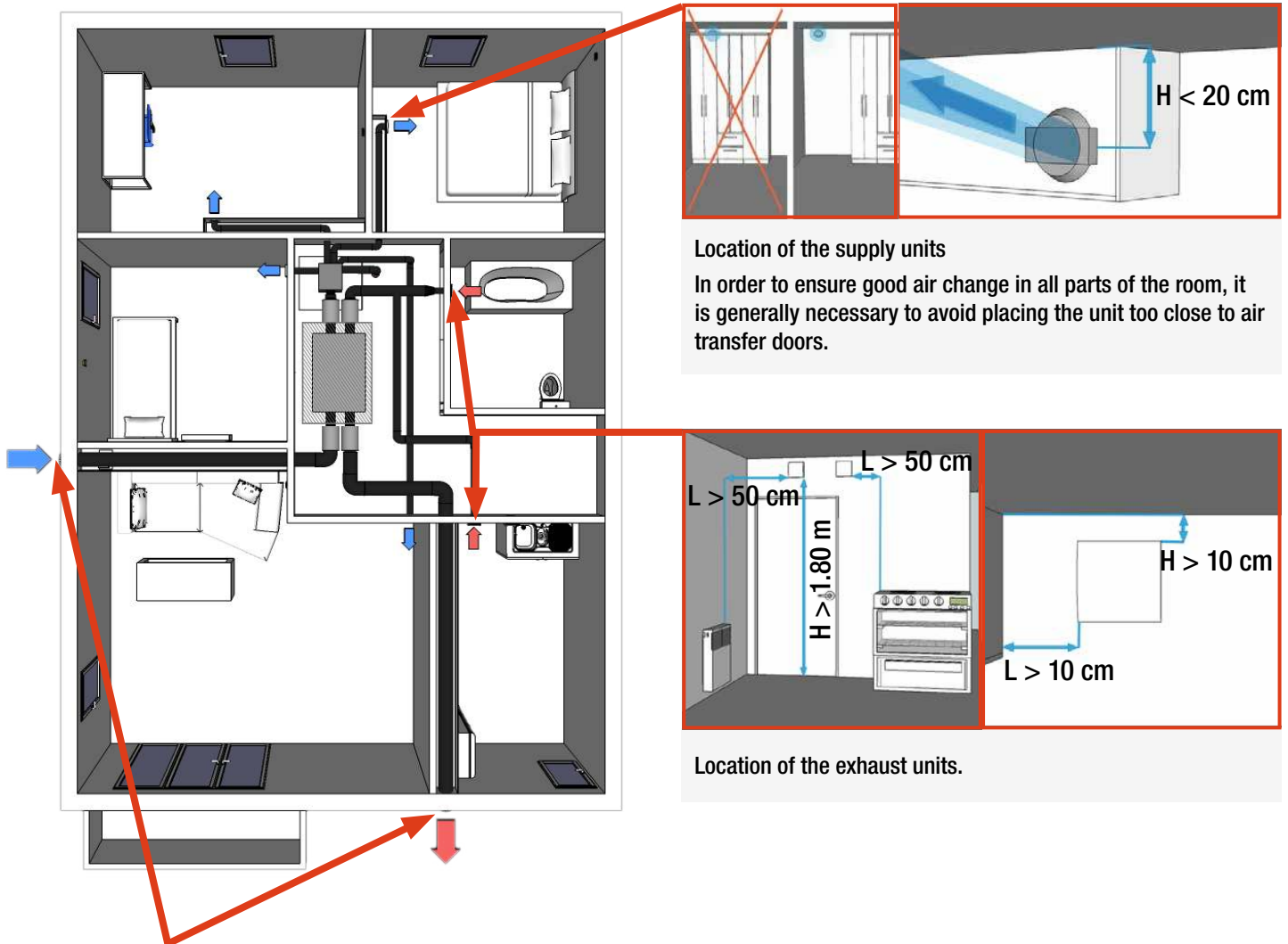

Location of the supply units
 In order to ensure good air change in all parts of the room, it is generally necessary to avoid placing the unit too close to air transfer doors.

Location of the exhaust units.
 L > 50 cm
 L > 50 cm
 H > 1.80 m
 H > 10 cm
 L > 10 cm

Requirement for fresh air inlet / exhaust air outlet grilles:
 · Ø 160 mm
 · less than 20 Pa at 230 m³/h

Units can be wall-mounted or installed in the ceiling; they must be readily accessible for cleaning (supply and exhaust units) and maintenance (replacement of the batteries in particular for the exhaust units).
 Generally speaking, avoid hindering the passage of the air by placing the units behind a cabinet or a household appliance.

 Any duct carrying hot air that is outdoors or in an unheated volume must be insulated with 50 mm of glass wool or equivalent. At supply and exhaust units, airflow must be adjusted by the installer. Desired flow rates may be achieved by the use of foam in the pipe or by the use of manual balancing register.

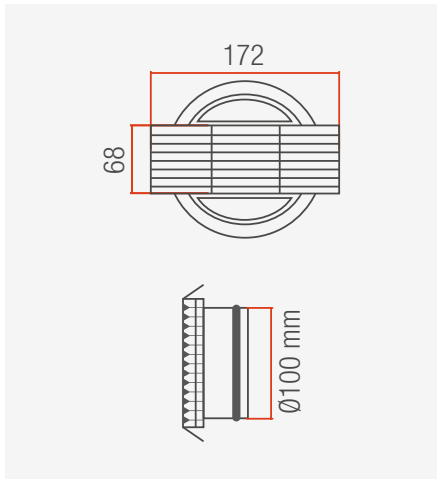

SDC 100 supply unit

12.1. SUPPLY UNITS / EXHAUST GRILLES

For good supply air distribution, it is important that the stream should be able to stick to the wall or ceiling. This requires placing the units less than 20 cm from the ceiling and making sure that the stream of air does not cause discomfort for the occupant (draught, etc.).

In order to ensure good air change in all parts of the room, it is generally necessary to avoid placing the unit too close to doors of the main rooms.

12.2. FRESH AIR INLET AND EXHAUST AIR OUTLET

The fresh air intake and the used air discharge must be in direct contact with the outdoor, and not in an attic, garage, or crawl space.

The fresh air intake of the installation must be:

- as far as possible from sources of pollution and air discharges (at least 3m from the ground);
- if possible, on a protected façade.

The exhaust air, for its part, must be far from air intakes (fresh air inlet, doors and windows); it must not be a nuisance for the occupants. If possible, use a different façade from the air intake in order to avoid mixing between the fresh air and the stale air.

We recommend taking the prevailing winds into account, in order to avoid an overpressure in the supply or exhaust duct (discharge up, or horizontal, and favourably oriented with respect to the prevailing winds).

Requirement for fresh air inlet / exhaust air outlet grilles:

- Ø 160 mm
- less than 20 Pa at 230 m³/h



The use of a double used air/fresh air duct is not recommended for this type of installation (Make sure that it avoids the mixing between the intake of fresh air and the discharge of used air).

13. ENVIRONMENTAL CONCERNS

Recycle of electrical and electronic equipment waste at the end of its lifecycle (applicable in the countries of the European Union and other countries with special collection centre).

The symbol on the appliance indicates that this appliance should not be treated as domestic waste. It must be taken to a special collection centre for the recycling of electrical and electronic equipment. For further information on the treatment, recovery and recycling of this product, contact your competent local office, the household waste collection service or the shop where you purchased the appliance.

14. WARRANTY

This guarantee is valid for 2 years from the original date of purchase of your appliance, for faults of the appliance, which have been caused by faulty construction. On these conditions, Aereco guarantee the replacement or the supply of the equipment found to be defective after inspection by its after sales service. In any case, the warranty may not cover additional costs, of labour, transport or compensation of any kind. The warranty does not cover damage due to improper installation in this manual, improper use or attempted repair by unauthorized personnel. In case of problems, please contact your installer or your reseller.



15. CONFORMITY AND STANDARD

The DXR Unit heat recovery system is CE certified. It has also received specific certifications in several countries (available on demand).

The choice of accessories associated with the heat recovery system must comply with the standards in force in the country, and preferably be certified, when such certification exists.

The DXR Unit complies with the following regulatory references:

Directives	Standards
EMC	EN 61000-6-3 : 2007 / A1 : 2011
	EN 61000-6-1 : 2007
	EN 62311 : 2008
Low voltage/LVD	DIN EN 60335-1 (VDE 0700-1):2012-10; EN 60335-1:2012
	DIN EN 60335-2-40 (VDE 0700-40):2010-03
	EN 62233 (VDE 0700-366):2008-11

16. CHARACTERISTICS

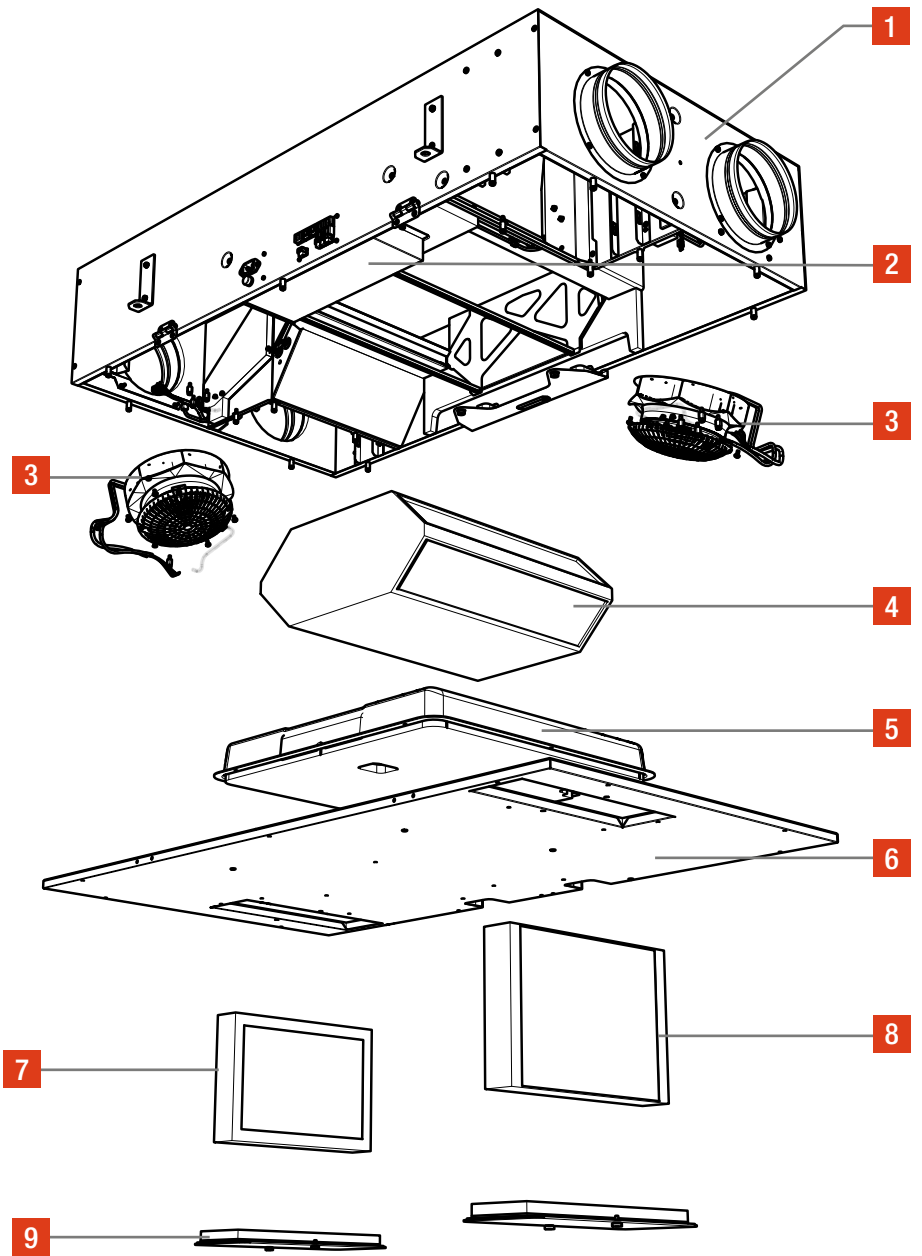

- 1** Base
- 2** Control and supply box
- 3** Fans
- 4** Heat exchanger
- 5** Condensates receiver
- 6** Bottom cover
- 7** G4 filters
- 8** F7 filter
- 9** Access hatches of the filters

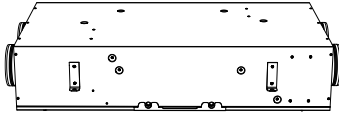

		DXR
Standard code		DXR1708
Ecodesign		
Label (EU Ecodesign Directive)		A
Airflow characteristics		
Max. airflow	m ³ /h	230
Other nominal airflows	m ³ /h	(40) 80 / 140 / 200 / 230 (250)
Airflow compensation (filter clogging)		automatic
Airflow balance (supply and exhaust)		automatic
Acoustics		
Sound power level L _w @ 161 m ³ /h, 50 Pa	dB(A)	40
Certifications		CE
Electrics		
Power supply		230 VAC, 50 Hz
Motor type		EC (x2)
Power consumption @ 161 m ³ /h @50 Pa	W	34,2
Power consumption @ 230 m ³ /h @145 Pa	W	91,0
Demand control		
Compatible versions of DX System		REFERENCE
Characteristics		
Exchanger		aluminium / counter flow type / 82% efficiency
Filters		on supply air: 1 x F7 / on exhaust air: 1 x G4
Weight	kg	46
Colour		galva
Material (main)		galvanised steel with phonic and thermal insulation
Dimensions	mm	with duct connectors: 260 x 650 x 1200 / without duct connectors: 260 x 650 x 1160
Installation		
Max. number of main rooms		6
Max. number of technical rooms		5
Connections		2 x (2 x ø160 mm)
Installation		horizontal only, to the ceiling / 4 points of attachment
Other functions		
Interface		Web pages
Bypass		controlled by outdoor temperature / also used for free cooling
Preheating (optional)		with resistance in fresh air ductwork from outside
Condensation management		exhaust through lateral tube / optional condensate pump
Temperature of use		
Installation room		frost free: +5°C < T° < +50°C
Incoming outdoor fresh air or Extract		-5°C < T° < +50°C without preheating / -26°C < T° < +50°C with preheating

DIMENSIONS IN MM : DXR UNIT

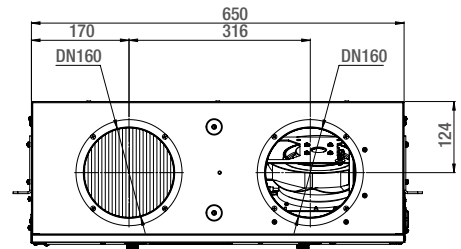
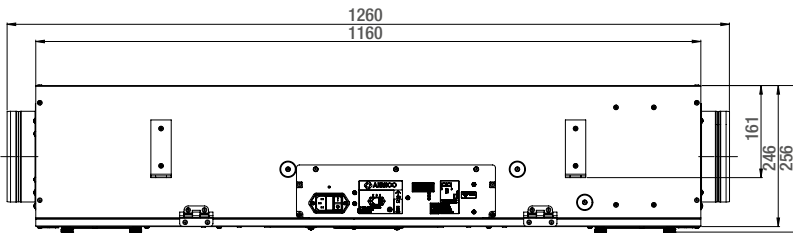
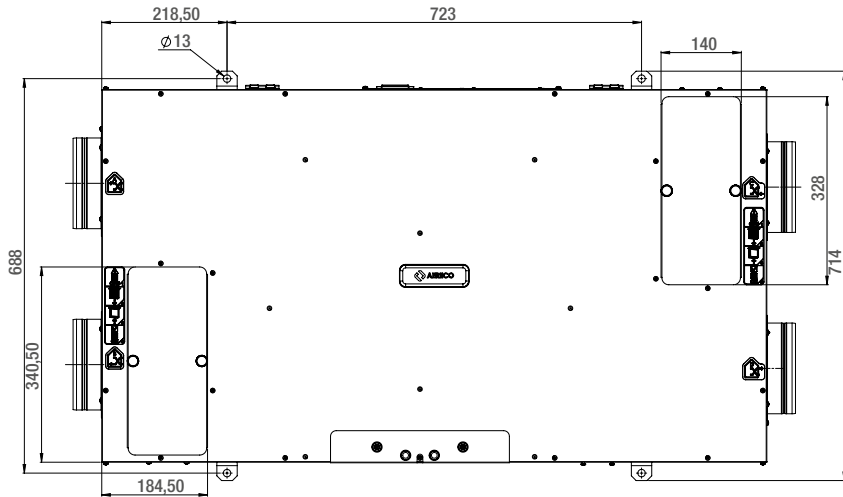

DXR UNIT: AERUALIC CURVES WITH SOUND POWER LEVEL VALUES

DXR UNIT: POWER CONSUMPTION CURVES

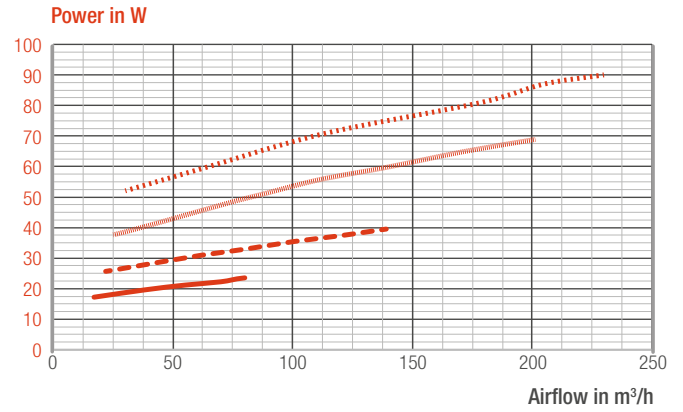
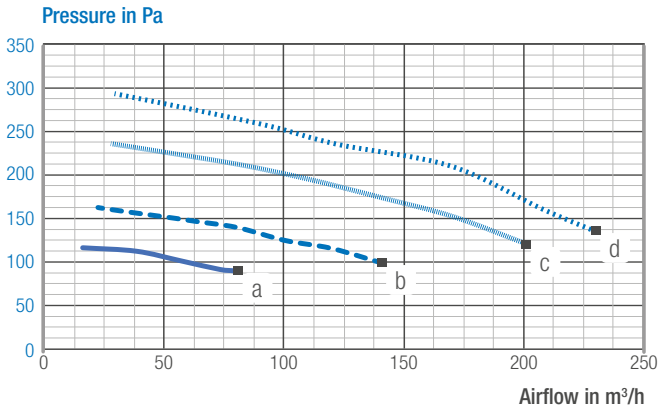

DXR Unit maximal airflow setting : Sound power level L_{wa}

— 80 m³/h	— 200 m³/h	a = 40 dB	c = 46 dB
- - 140 m³/h	· · · 230 m³/h	b = 43 dB	d = 49 dB

DXR Unit maximal airflow setting :

— 80 m³/h	— 200 m³/h
- - 140 m³/h	· · · 230 m³/h



Aereco S.A.
62 rue de Lamirault
Collégien
77615 MARNE LA VALLEE CEDEX 3
FRANCE
www.aereco.com